

Temperature and air velocity transmitter

CTV 110

KEY POINTS

- Measuring range from 0 to 30 m/s and from 0 to 50 °C
- 0-10 V or 4-20 mA output, active, power supply 24 Vac/Vdc (3-4 wires)
- ABS V0 housing, IP65, with or without display
- Alternating display of air velocity and temperature
- "¼ turn" system mounting with wall-mount plate
- Housing with simplified mounting system



FEATURES OF THE HOUSING

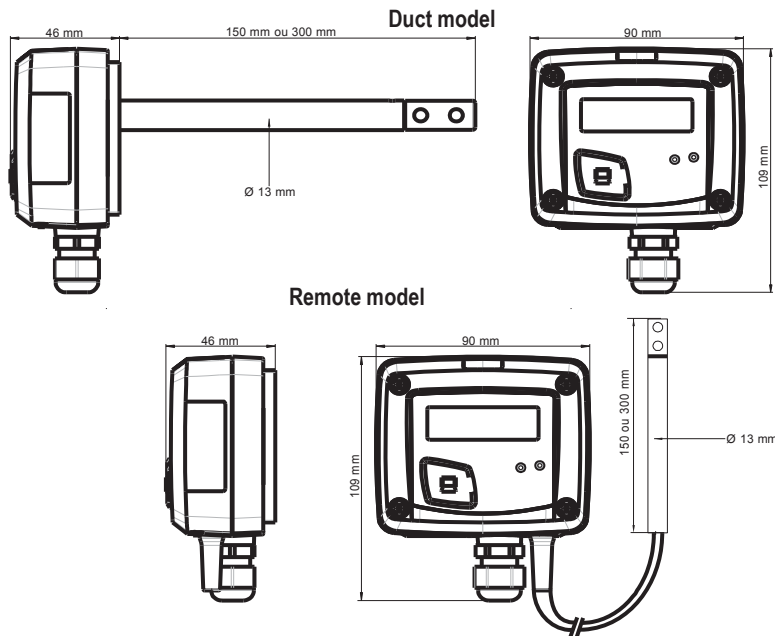

Material

ABS V0 as per UL94

Protection

IP65

Display

LCD 10 digits. Size : 50 x 17 mm

Alternating display of air velocity and temperature

Height of digits

Values : 10 mm

Units : 5 mm

Cable gland

For cable Ø 8 mm maximum

Weight

164 g

Cable of remote probe : length 2 m and Ø 4.8 mm in PVC

PART NUMBER

To order, just add the codes to complete the part number :

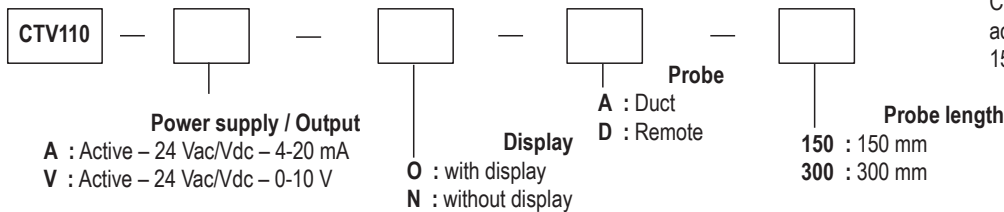

Example : CTV 110 - AOD150

CTV110 temperature and air velocity transmitter, active 4-20 mA, with display and remote probe of 150 mm length

TECHNICAL FEATURES IN TEMPERATURE

Measuring range	From 0 to 50 °C (possibility to set the output on the following ranges : from -20 to +80 °C, from -50 to +50 °C and from 0 to +100 °C)
Accuracy*	±0.3% of reading ±0.25 °C
Unit of measurement	°C, °F
Response time	1/e (63%) 5 s
Type of sensor	Pt100 1/3 DIN
Resolution	0.1 °C
Type of fluid	Air and neutral gases

*All the accuracies indicated in this technical datasheet were stated in laboratory conditions, and can be guaranteed for measurements carried out in the same conditions, or carried out with calibration compensation.

TECHNICAL FEATURES IN AIR VELOCITY

Outputs settings	From 0 to 5m/s, from 0 to 10 m/s, from 0 to 15 m/s, from 0 to 20 m/s and from 0 to 30 m/s
Accuracy*	From 0 to 3 m/s : $\pm 3\%$ of reading ± 0.05 m/s From 3 to 30 m/s : $\pm 3\%$ of reading ± 0.2 m/s
Units of measurement	m/s and fpm
Response time	1/e (63%) 2 s
Resolution	From 0 to 3 m/s : 0.01 m/s From 3 to 30 m/s : 0.1 m/s
Type of fluid	Air and neutral gases

TECHNICAL SPECIFICATIONS

Output / Power supply	- active sensor 0-10 V or 4-20 mA (alim. 24 Vac/Vdc $\pm 10\%$), 3-4 wires - maximum load : 500 Ohms (4-20 mA) - minimum load : 1 K Ohms (0-10 V)
Consumption	40 mA (0-10 V) or max. 80 mA (4-20 mA)
Electromagnetical compatibility	EN61326
Electrical connection	Screw terminal block for cables $\varnothing 0.05$ to 2.5 mm ²
PC communication	Kimo USB-mini Din cable
Environment	Air and neutral gases
Operating temperature	From 0 to +50 °C
Storage temperature	From -10 to +70 °C

ELECTRICAL CONNECTIONS – as per *NFC15-100 standard*



This connection must be made by a qualified technician. **To make the connection, the transmitter must not be energized.**

For **CTV110-VNA, CTV110-VND, CTV110-VOA, CTV110-VOD** models with **0-10 V** output – active :

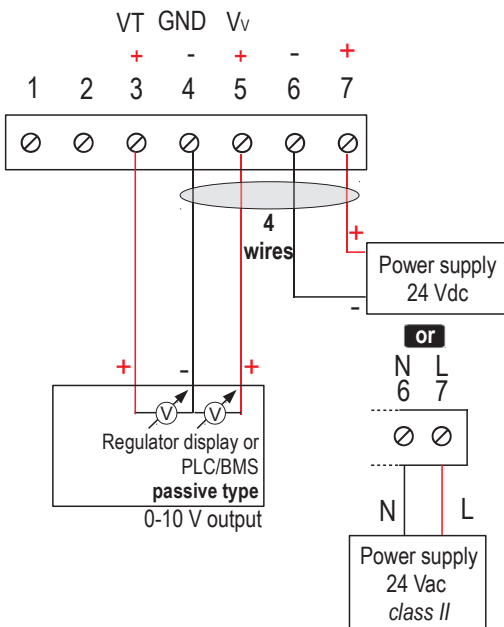

4 wires



To make a 3-wire connection, before powering up the transmitter, please connect the output ground to the input ground. See drawing below.

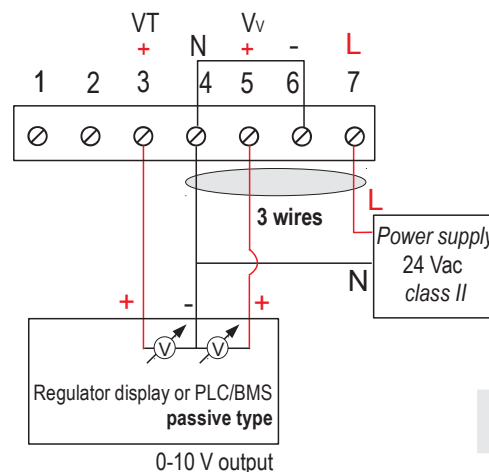
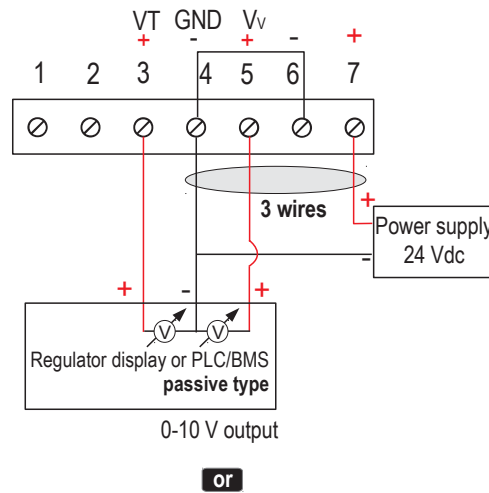

3 wires

For CTV110-ANA, CTV110-AND, CTV110-AOA, CTV110-AOD models with 4-20 mA output – active :

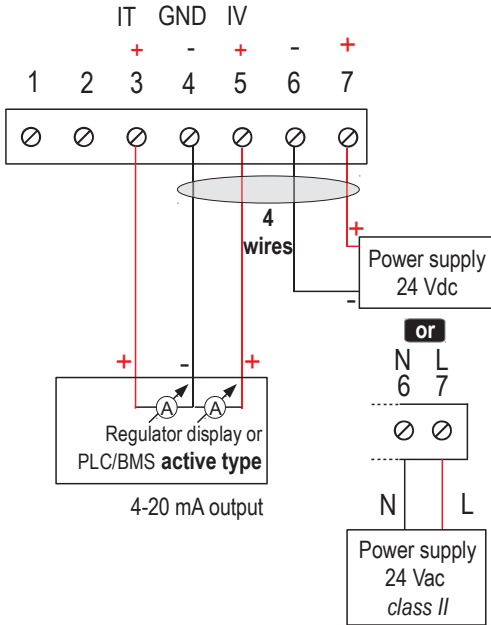

To make a 3-wire connection, before powering up the transmitter, please connect the output ground to the input ground. See drawing below.

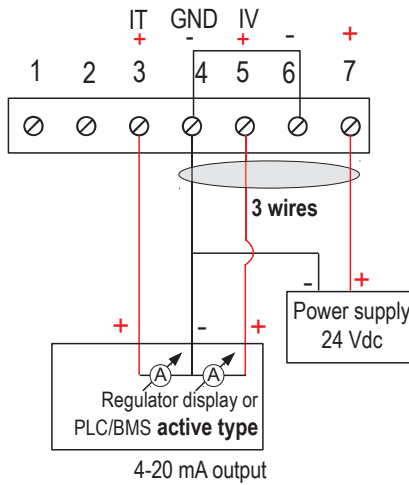

OR

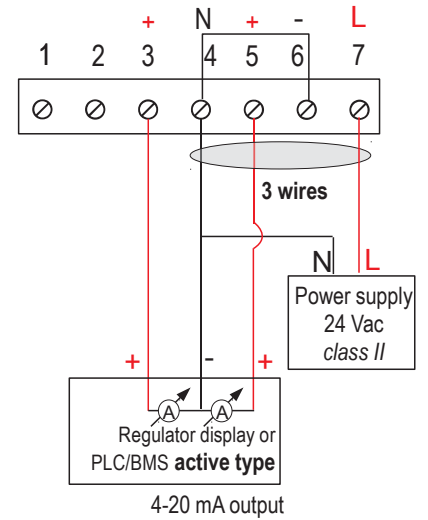

4 wires

3 wires

CONNECTIONS

Inside the front housing

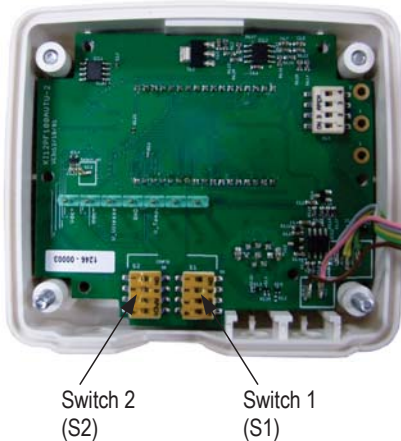

Removable front face



Fixed back housing

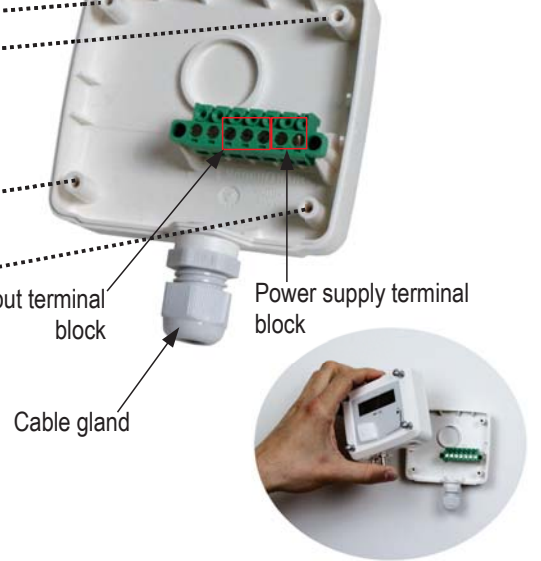

SETTINGS AND USE OF THE TRANSMITTER

> Configuration

It is possible to configure the measuring ranges and the units of the transmitter via switch and/or software.



To configure the transmitter, it must not be energized. Then, you can make the settings required, with the DIP switches (as shown on the drawing below). When the transmitter is configured, you can power it up.

> Configuration by switch

To configure the transmitter, unscrew the 4 screws from the housing then open it. DIP switches allowing the different settings are then accessible.



Please follow carefully the combinations beside with the DIP switch. If the combination is wrongly done, the following message will appear on the display of the transmitter "CONF ERROR". In that case, you will have to unplug the transmitter, place the DIP switches correctly, and then power the transmitter up.

On-off switch

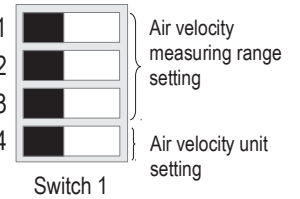
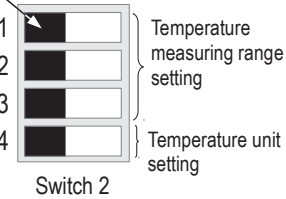

> Air velocity unit setting – switch 1

To set a measurement unit in air velocity, put the on-off switch 4 of the units as shown in the table beside.

Configurations	m/s	fpm
1	<input type="checkbox"/>	1 <input type="checkbox"/>
2	<input type="checkbox"/>	2 <input type="checkbox"/>
3	<input type="checkbox"/>	3 <input type="checkbox"/>
4	<input type="checkbox"/>	4 <input type="checkbox"/>

> **Outputs setting in air velocity – switch 1**

To set a measuring range, put the on-off switches 1, 2 and 3 as shown beside.

Configurations	From 0 to 5 m/s	From 0 to 10 m/s	From 0 to 15 m/s	From 0 to 20 m/s	From 0 to 30 m/s
Combinations	1	1	1	1	1
	2	2	2	2	2
	3	3	3	3	3
	4	4	4	4	4

> **Setting of temperature unit – switch 2**

To set the temperature unit, put the on-off switch 4 of the unit as shown beside.

Configurations	°C	°F
Combinations	1	1
	2	2
	3	3
	4	4

> **Outputs setting in temperature – switch 2**

To set a measuring range in temperature, put the on-off switches 1, 2 and 3 of the measuring ranges as shown beside.

Configurations	From 0 to +50°C	From -20 to +80°C	From -50 to +50°C	From 0 to 100°C	From 0 to 200°C
Combinations	1	1	1	1	1
	2	2	2	2	2
	3	3	3	3	3
	4	4	4	4	4

CONFIGURATION VIA LCC-S SOFTWARE (option)

An easy and friendly configuration with the software !

You can configure your own intermediary ranges.

Example : for a 0-30 m/s transmitter, the minimum delta of the range is 5 m/s. The instrument could be then configured from 5 to 10 m/s.

- To access the configuration via software :
 - Set the DIP switches as shown beside.
 - Connect the cable of the LCC-S to the connection of the transmitter.
- Please refer to the user manual of the LCC 100 to make the configuration.

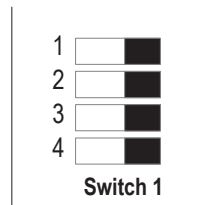

The configuration of the parameters can be done either with the DIP switch or via software (you can not combine both solutions).

MOUNTING

To mount the transmitter, mount the ABS plate on the wall (drilling : Ø6 mm, screws and pins are supplied). Insert the transmitter on the fixing plate (see A on the drawing beside). Rotate the housing in clockwise direction until you hear a “click” which confirms that the transmitter is correctly installed.

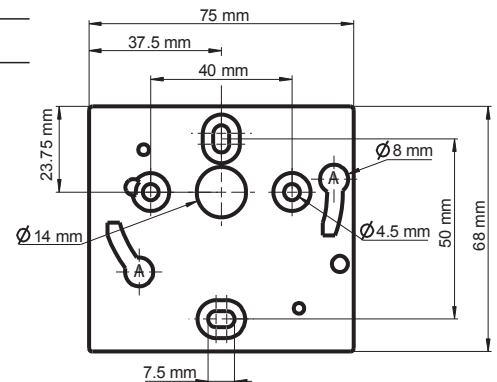

Positioning of the measuring element in the air flow :

The probe must be placed perpendicular to the air flow, as shown beside. For the duct mount probes, it is possible to place the probe's head front of the air flow, and keep the housing straight :

- > Locate the red point marked on the probe's head.
- > Remove the screw located on the tip of the probe's body.
- > Rotate the probe's head by ¼ turn, ½ turn or ¾ turn, in order to place the red spot front to the air flow.
- > Replace the screw on the probe's body.

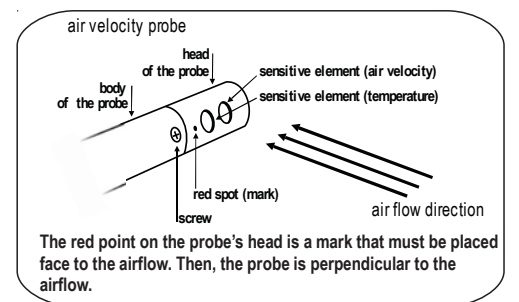

MAINTENANCE

Please avoid any aggressive solvent. Please protect the transmitter and its probes from any cleaning product containing formalin, that may be used for cleaning rooms or ducts.

OPTIONS AND ACCESSORIES

- **KIAL-100A** : Power supply class 2 , 230 Vac input, 24 Vac output
- **LCC-S** : configuration software with USB cable
- Sliding fittings, mounting brackets, wall-mount support for hotwire probes

www.kimo.fr

Distributed by :



EXPORT DEPARTMENT
 Tel : + 33. 1. 60. 06. 69. 25 - Fax : + 33. 1. 60. 06. 69. 29
 e-mail : export@kimo.fr