

## Pitot tube Type L

**Pitot tube Type L**

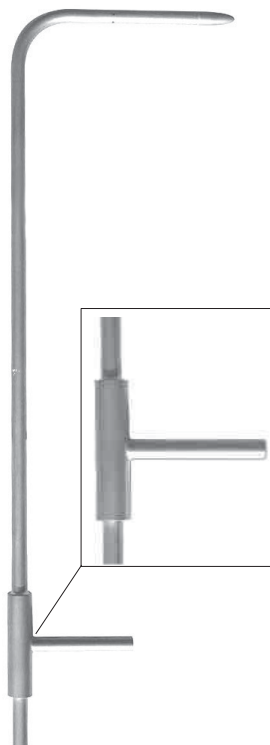

**Pitot tube** with ellipsoidal head.  
An intake for total pressure and 6 holes for static pressure.  
Body made of stainless steel.

**Pitot tube Type L with TC K**

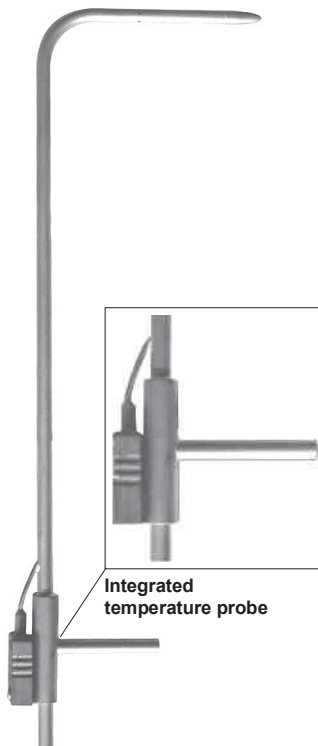

**Pitot tube** with ellipsoidal head.  
An intake for total pressure and 6 holes for static pressure.  
Sheathed thermocouple K probe integrated, with connection cable length 1,5 m.  
Body made of stainless steel.

### Features

<b>Norm</b> .....	AFNOR NFX10-112. Annex 4 dated 14.9.77. This norm meets the requirements of the International Norm ISO 3966.
<b>Model</b> .....	NPL curved with ellipsoidal head
<b>Coefficient</b> .....	1,0015±0,01
<b>Accuracy</b> .....	More than 1 %, for a ± 10 ° alignment to the fluid flow.
<b>Quality</b> .....	stainless steel 316 L
<b>Operating temperature</b> .....	from 0 to 600 °C in standard and up to 1000 °C in option (except Ø 3 mm).



- The extent error of an air velocity or airflow measurement with a KIMO Pitot tube remains inferior to 2%, when being carried out as per the NFX10-112 norm.
- It is recommended to carry out a calibration of the Pitot tube, in order to determine its exact coefficient.

### Presentation

KIMO offers a wide range of high-quality and accurate **Pitot tubes**, as per the AFNOR NFX 10-112 norm.

These **Pitot tubes**, when being connected to a differential column / or needle / or electronic manometer, can measure the dynamic pressure of a moving fluid in a duct, and then can deduct its air velocity in m/s and its airflow in m<sup>3</sup>/h.

These **Pitot tubes** are used in HVAC field, vacuum cleaning and pneumatical transport. They are mainly dedicated to measure hot and particle-charged air, and also high air velocity.



## Dimensions

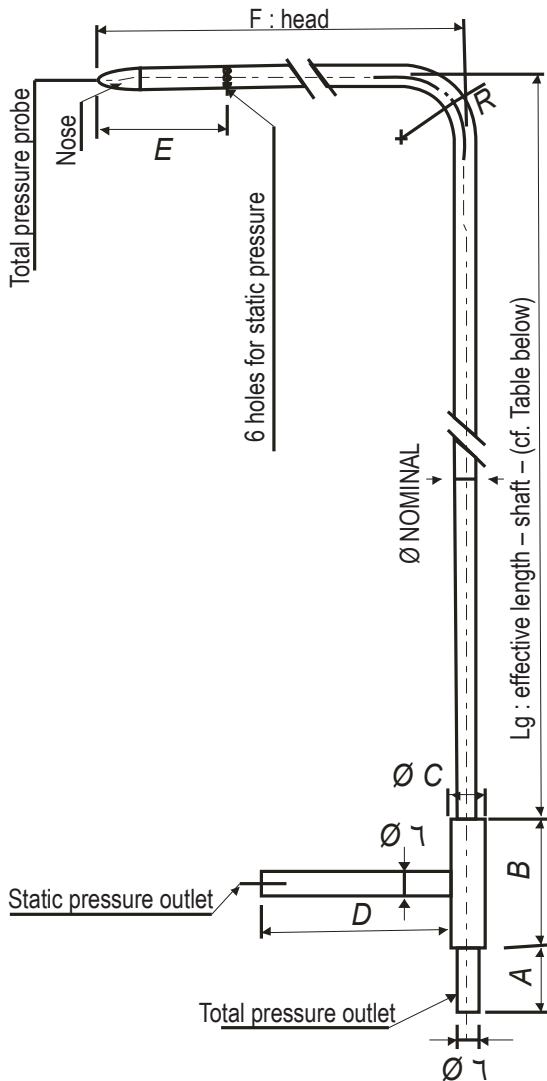

**Pitot tube Type L**

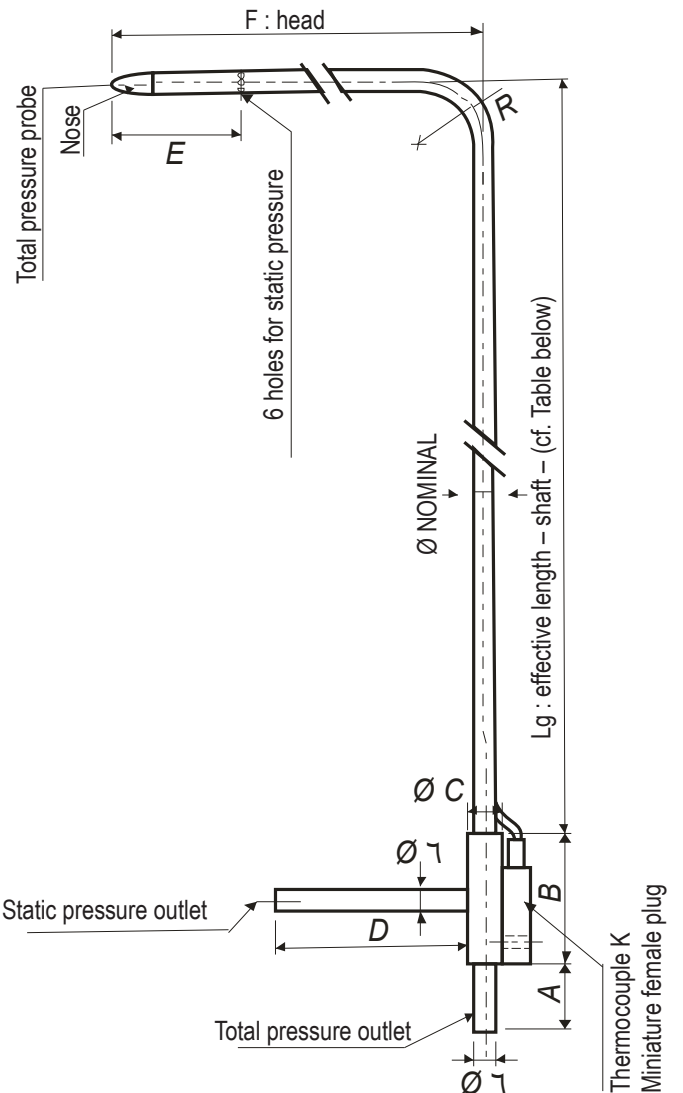

**Pitot tube Type L with TC K**

	A	B	ØC	D	E	F	R
Pitot tube Ø 6 mm	17	32	10	30	48	96	18
Pitot tube Ø 6 mm	25	40	10	45	48	96	18
Pitot tube Ø 8 mm	25	40	10	45	64	128	24
Pitot tube Ø 12 mm	25	50	16	60	96	192	36
Pitot tube Ø 14 mm	25	50	16	60	112	224	42

## Ranges

**Pitot tube Type L**

Diameter	Reference	Length
Ø 3 mm	TPL-03-100	100 mm
	TPL-03-200	200 mm
	TPL-03-300	300 mm
Ø 6 mm	TPL-06-300	300mm
	TPL-06-500	500 mm
	TPL-06-800	800 mm
Ø 8 mm	TPL-08-1000	1000 mm
	TPL-08-1250	1250 mm
Ø 12 mm	TPL-12-1500	1500 mm
	TPL-12-2000	2000 mm
Ø 14 mm	TPL-14-2500	2500 mm
	TPL-14-3000	3000 mm

**Pitot tube Type L with TC K**

Diameter	Reference	Length
Ø 3 mm	TPL-03-100-T	100 mm
	TPL-03-200-T	200 mm
	TPL-03-300-T	300 mm
Ø 6 mm	TPL-06-300-T	300 mm
	TPL-06-500-T	500 mm
	TPL-06-800-T	800 mm
Ø 8 mm	TPL-08-1000-T	1000 mm
	TPL-08-1250-T	1250 mm
Ø 12 mm	TPL-12-1500-T	1500 mm
	TPL-12-2000-T	2000 mm
Ø 14 mm	TPL-14-2500-T	2500 mm
	TPL-14-3000-T	3000 mm

## Operating

The **Pitot tube** must be introduced perpendicularly into the duct, in several points pre-determined (see table "location of measuring points").

The head (ending with an ellipsoidal nose) must be maintained parallel and facing the flow.

The total pressure (+) caught by the nose, is connected to the + of the manometer

The static pressure (-) caught by the holes of the head, is connected to the - of the manometer.

The connection cable of the thermocouple K probe is connected to the thermocouple K inlet of the manometer (only on the **Pitot type L with TC K**).

Then, the instrument can display the dynamic pressure, also named "velocity pressure".

The dynamic pressure corresponds to the difference between the total pressure and the static pressure :  $Pd = Pt - Ps$

### Schema

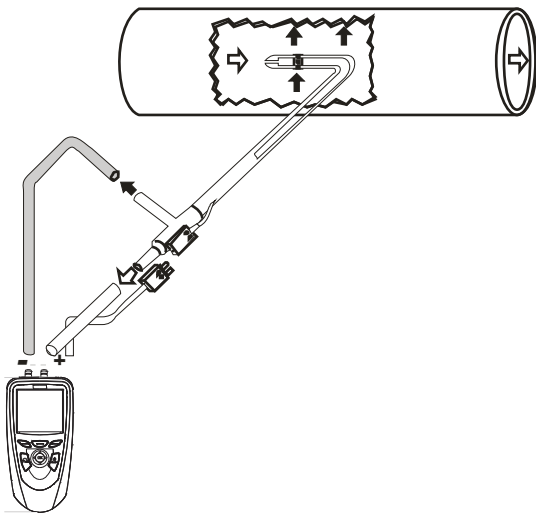

- ⇨ Total pressure (Pt)
- ➔ Static pressure (Ps)

$$\text{Dynamic pressure} = Pt - Ps$$

Example :

The manometer model MP200 directly displays the velocity in m/s.

### Location of measuring points

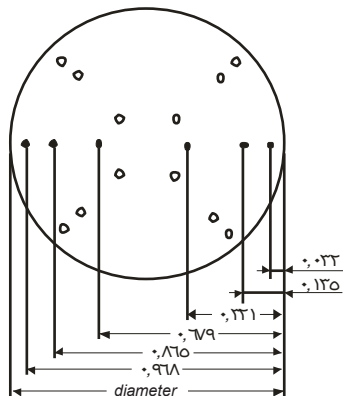
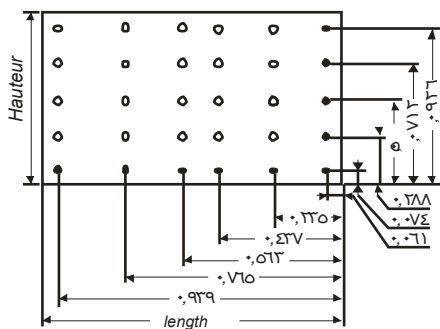

With the dynamic pressure in mm H<sub>2</sub>O or in Pa, we can calculate the air velocity in m/s, with the simplified BERNOULLI formula :

$$V \text{ in m/s à } 20^\circ\text{C} : 1,291 \sqrt{Pd \text{ in Pa}}$$

or

$$V \text{ in m/s} : 4,05 \sqrt{\Delta P \text{ en mm CE}}$$

**Formula to get the velocity, with temperature balancing of the airflow :**

$$V \text{ in m/s} = K \times \sqrt{\frac{574,2 \Theta + 156842,77}{P_0} \times \Delta P \text{ in Pa}}$$

**With**

$P_0$  = barometric pressure in Pa

$\Theta$  = temperature in °C

K = coefficient of the Pitot tube

## ■ Accessories

- Connection glands made of nickel plated brass (to install the Pitot tube in a fixed location)
- Clamp made of stainless steel and cast iron
- Sliding connections with nipple, made of stainless steel or Teflon
- Extension cable for thermocouple K class 1 :
- Rubber sealing caps : come in a 10-unit bag
- Caps : come in a 10-unit bag
- Graduation (mm) red-marked on the shaft
- Tubes

- Straight **Pitot tube type L** and **type L with TC K** :

You can directly make the measurements by plunging this tube into the air duct.

Diameters and dimensions : same as the **Pitot tube** NPL curved.



Feel free to contact KIMO for any special case, any special manufacturing.

[www.kimo.fr](http://www.kimo.fr)

### EXPORT DEPARTMENT

Tel : + 33. 1. 60. 06. 69. 25 - Fax : + 33. 1. 60. 06. 69. 29

e-mail : [export@kimo.fr](mailto:export@kimo.fr)



Distributed by : **PRC Technologies Corp., Ltd.**

Tel : 02 530 1714, 02 530 1619, 02 530 1621

Fax : 02 530 1731

[info@prctechth.com](mailto:info@prctechth.com) [www.prctechth.com](http://www.prctechth.com)