

Product Information

Sensors and Instrumentation

Flow Switch
UR1- / UR2-...G / A



- Low pressure loss
- Compact design
- Threaded connection

Characteristics

The devices function via the principle of a spring-supported paddle, and the magnetic triggering of a reed switch.

Technical data

Switch	reed switch	
Nominal width	DN 10..50	
Process connection	brass / stainless steel - female thread G 3/8..G 1 brass / POM - male thread G 1/2 A (further process connections available on request)	
Switching range	1.3..35 l/min	for details see table "Ranges"
Q_{max.}	to 150 l/min	
Tolerance	±15 % of full scale value	
Pressure	Brass	PN 25 (UR1)
	Stainless steel	
	POM	PN 10 (UR2)
	PPS	
Medium temperature	-20..+110 °C (optionally 150 °C)	
Ambient temperature	-20..+70 °C	
Media	water (oils, gases and aggressive media available on request)	
Electrical data	see "UR1 brass switching unit" or "UR1 plastic switching unit"	
Materials medium-contact	<i>Brass construction:</i> CW617N nickelled, CW614N nickelled, 1.4310, 1.4301, hard ferrite, NBR	<i>Stainless steel construction:</i> 1.4305, 1.4571, 1.4310, 1.4310, hard ferrite PTFE-coated, FKM
	<i>Optional:</i> Body made from POM (PN 10) Body made from PPS (PN 10) Connection G 1/2 A POM (PN 10)	
Non-medium-contact materials	see "UR1 brass switching unit" or "UR1 plastic switching unit"	
Weight	see table "Dimensions and weights"	

Installation location	Standard: horizontal inwards flow; switching unit not recommended underneath; other installation positions are possible; the installation position affects the switching point and range
------------------------------	--

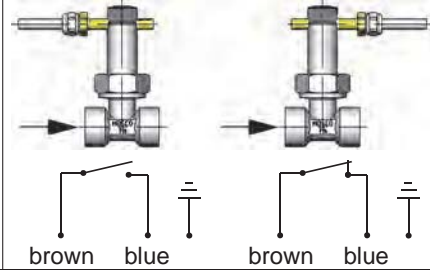
UR1 Brass switching unit	
Wiring	normally open (n.o.) or normally closed (n.c.), no. 0.225 
Switching voltage	max. 230 V AC
Switching current	max. 1 A
Switching capacity	max. 50 VA
Protection class	1 - PE connection
Ingress protection	IP 65
Electrical connection	cable 1.5 m, optionally for round plug connector M12x1, 4-pole
Materials, non-medium-contact	CW614N, nickelled, CW614N, NBR, PVC, POM

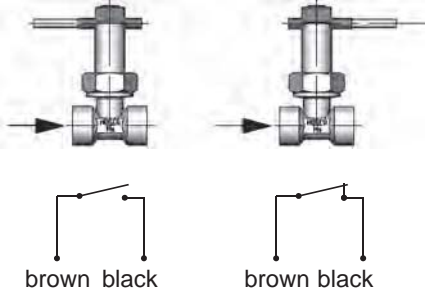
UR2 Plastic switching unit	
Wiring	
Switching voltage	max. 230 V AC
Switching current	max. 1 A
Switching capacity	max. 50 VA
Protection class	2 - safety insulation
Ingress protection	IP 65
Electrical connection	cable 1.5 m
Materials, non-medium-contact	PA, PVC, POM

Product Information

Sensors and Instrumentation

Ranges

Details in the table correspond to horizontal inwards flow with decreasing flow rate.

UR2 (Plastic switching unit) is adjusted in the factory; please specify switching value.

G	DN	Switching range l/min H ₂ O	Types	Q _{max.} recommended
G 3/8	DN 10	2.5 - 3.5	UR.-010G.	10
G 1/2 A	DN 15	1.3 - 2.1	UR.-015A.	
G 1/2		4.0 - 4.5	UR.-015G.	
G 3/4	DN 20	5.0 - 6.0	UR.-020G.	20
G 1	DN 25	9.5 - 11.5	UR.-025G.	40
G 1 1/4	DN 32	13.5 - 17.5	UR.-032G.	60
G 1 1/2	DN 40	30.0 - 38.0	UR.-040G.	80
G 2	DN 50	42.0 - 53.0	UR.-050G.	100
				150

Special ranges are available.

Dimensions and weights

G	Types	H	L	X	Weight kg	
					UR1	UR2
G 3/8	UR.-010GM	82	50	10	0.35	0.35
	UR.-010GK				0.40	0.40
G 1/2 A	UR.-015AM		60	12	0.35	0.30
	UR.-015AP				0.15	0.15
G 1/2	UR.-015GM	50	50	10	0.35	0.30
	UR.-015GK				0.40	0.40
G 3/4	UR.-020GM	83	12		0.35	0.35
	UR.-020GK					
G 1	UR.-025GM	87			0.40	0.40
	UR.-025GK				0.45	0.45
G 1 1/4	UR.-032GM	91				0.40
	UR.-032GK				0.50	0.50
G 1 1/2	UR.-040GM	94			0.55	
	UR.-040GK				0.65	0.65
G 2	UR.-050GM	103			0.80	0.75
	UR.-050GK				0.95	0.95

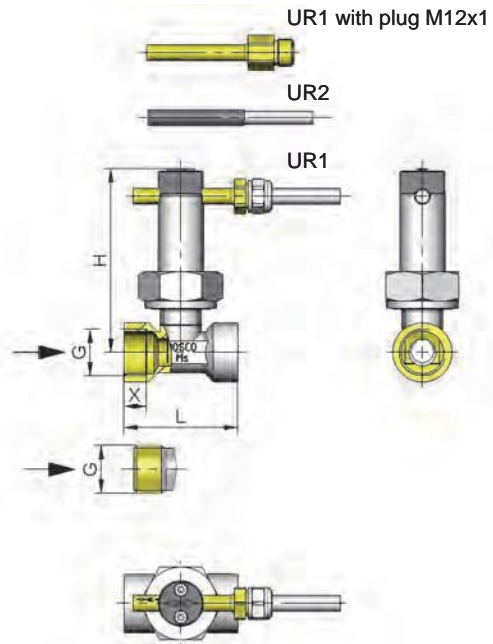

Handling and operation

Note

- Include straight calming section of 5 x DN in inlet and outlet
- Include a filter if the media are dirty (use magnetic filter for ferritic components).
- It must be ensured that the values given for voltage, current, and power are not exceeded.
- When switched on, a load must be connected in series.
- The electrical details apply to ohmic loads. Capacitive, inductive and lamp loads must be operated using a protective circuit.

Adjustment

UR1 - loosen bolts, push the switching current tube into the desired position. Retighten the bolts. Normally closed (n.c.) or normally open (n.o.) as per table "Technical data"

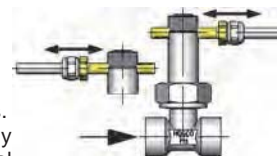

Product Information

Sensors and Instrumentation

Ordering code

UR 1. - 2. 3. 4. 5.

○=Option

1. Switching unit				
1	brass			
2	○ plastic (already adjusted, specify switching value and normally closed (n.c.) or normally open (n.o.))			
2. Nominal width				
010	DN 10 - G $\frac{3}{8}$	●	●	
015	DN 15 - G $\frac{1}{2}$	●	●	
	DN 15 - G $\frac{1}{2}$ A		●	●
020	DN 20 - G $\frac{3}{4}$	●	●	
025	DN 25 - G 1	●	●	
032	DN 32 - G $1\frac{1}{4}$	●	●	
040	DN 40 - G $1\frac{1}{2}$	●	●	
050	DN 50 - G 2	●	●	
3. Process connection				
G	female thread	●	●	
A	male thread		●	●
4. Connection material				
M	brass			
K	stainless steel			
P	POM (PN 10)			
5. Switching unit options				
A	for switching unit ATEX A-U1.1 The switching head is ordered in addition.			
S	○ for round plug connector M12x1, 4-pole			

Options

- Switching ranges for oil or gas
- Special values
- Soldered copper fitting
- Adhesive PVC fitting

Ordering information

- Specify direction of flow, medium, and switching range, UR1 or switching value UR2.
- For UR2 specify normally closed (n.c.) or normally open (n.o.).
- For oils, state viscosity, temperature and designation (e.g. ISO VG 68) (enquire about range).
- For gases, state pressure (relative or absolute), temperature and medium (e.g. air) (enquire about range).

Product Information

Sensors and Instrumentation

Switching Head A-U1-1

For device UR1



- I M1 Ex ia I
- II 1G Ex ia IIC T4
- II 1D Ex iaD 20 T135

Characteristics

Intrinsically safe switching unit with reed switch and ATEX approval, for the UR1 range of devices, for use in intrinsically safe power circuits.

Technical data

Switch	reed switch
Medium temperature	-20..+110 °C
Ambient temperature	-20..+50 °C
Weight	0.05 kg additionally
Wiring	normally opened (n.o.) or normally closed (n.c.), no. 0.442
Switching voltage	max. 30 V
Switching current	max. 1.5 A
Switching capacity	max. 45 W
Ingress protection	IP 65
Electrical connection	cable 2.5 m, other cable lengths up to max. 5 m are optionally available

Dimensions

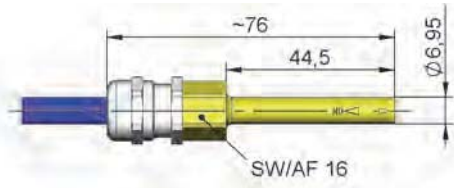

Handling and operation

Note

- For use only in intrinsically safe power circuits - Provide a suitable isolating amplifier.
- Cable lengths max. 5 m.
- It must be ensured that the values given for voltage, current, and power are not exceeded.
- When switched on, a load must be connected in series.
- The electrical details apply to ohmic loads. Capacitive, inductive and lamp loads must be operated using a protective circuit.

Adjustment

Loosen bolt(s), push the switching current tube into the desired position. Retighten the bolt(s). Normally closed (n.c.) or normally opened (n.o.) as per table "Technical data"

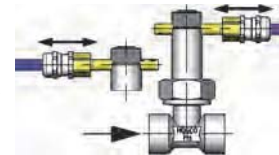

Ordering code

The base device is ordered, e.g. UR1-015GMA with switching head A-U1-1.

A-U1 - ^{1.} 1

1. Device series	
1	for UR1