

# Flow - gearwheel



## Characteristics

<b>System</b>	Volumetric metering system for self-lubricating fluids (oils, ..), excellent viscosity independence.
<b>Evaluation</b>	Display, switching Metering, counting
<b>Nominal widths</b>	DN 8..25
<b>Range</b>	0.04..150 l/min
<b>Pressure resistance</b>	Max. 200 bar
<b>Medium temperature</b>	-20..+120 °C
<b>Materials</b>	Al anodised, steel, stainless steel

## Applications

- Lubrication applications
- Position monitoring (via hydraulics)
- Metering of present value
- Totalisation
- Batch counting, filling applications
- Consumption metering
- Positioning of cylinders
- Lubrication equipment
- Dry-run protection

## Function and benefits

The VHS measurement systems have been designed for flow measurement and monitoring of viscous, self-lubricating media (oils, etc.). The fluid fills the defined space between the gears and the wall, and is transported onwards by its own energy of flow. Here, a magnetically pre-tensioned Hall sensor detects a pulse according to the intermediate gear volumes transported. The current value is proportional to the detected frequency.



- Ranges from 0.04..150 l/min (G 1/4..G 1)
- Large viscosity independence due to volumetric measurement process (fluids, oils, paints, pastes with self-lubricating character).
- Precision better than 3 % of the measurement value (better with higher viscosities)
- Low production spread
- Position-independent operation
- Bi-directional operation possible (with A / B signals, direction detectable)
- Intrinsically safe behaviour (operational failure creates error message)
- No magnets in the flow area (detection by external pre-tensioned Hall sensor)
- Operating pressure up to 200 bar
- Temperature range up to 150 °C
- Frequency output in a wide range linear (measurement range 1:50)
- Analog measuring transducer through screw-on electronics or possible with external converter (then a display and switching points can also be realised)
- LABO, FLEX, OMNI compatible
- Universal local counters possible

With oils, for example, different viscosities arise as operating temperatures vary. Here, in addition to the Coriolis principle, the volumetric principle offers the best measurement results. The diagram shows good independence from viscosity. The higher the viscosity, the smaller the leakage error.

### Diagrams

#### Pressure loss / Viscosity / Flow rate

The pressure loss results from the flow rate and the viscosity of the fluid being measured. Larger viscosities create larger pressure losses. Higher viscosities than those listed here are easily possible, but require a higher pump capacity.

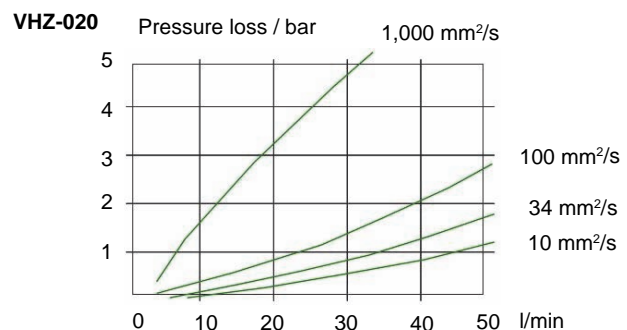
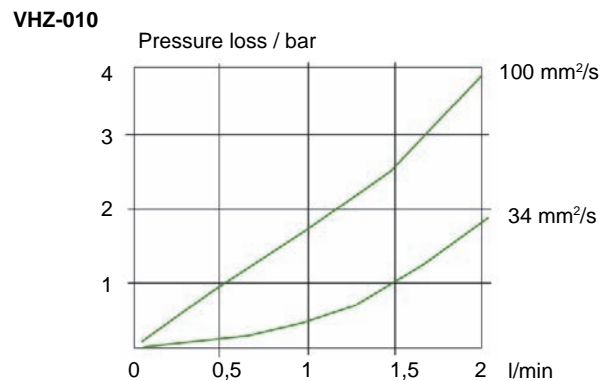
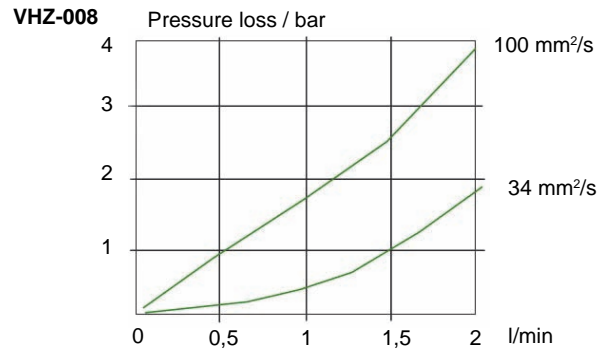

**Product Information**

**Sensors and Instrumentation**

**VHZ-025**

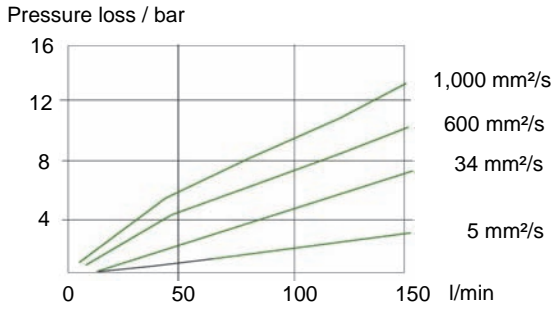

**Intermediate gear volume and flow rate**

This ratio indicates the precision of the flow meter. With a limited metering range, greater precision can be provided. The precision also improves as the viscosity increases (test viscosity for the represented curves is 20 mm<sup>2</sup>/s).

**VHZ-008**

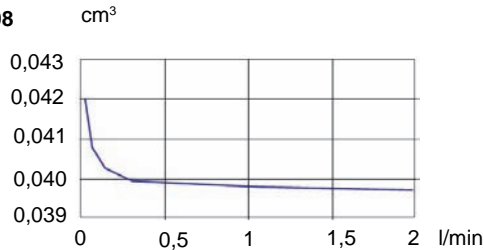

**VHZ-010**

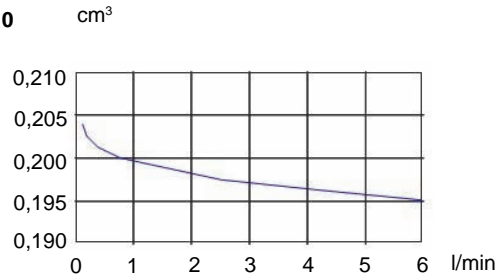

**VHZ-020**

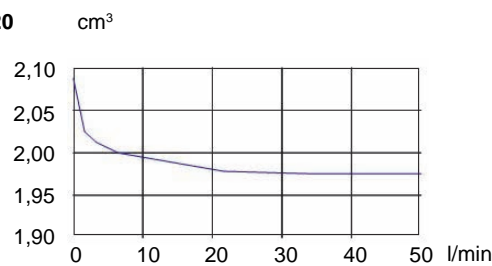

**VHZ-025**

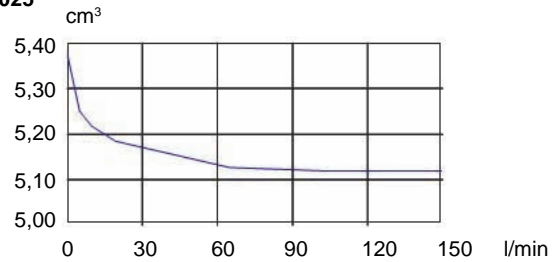

**Noise level and flow rate**

**VHZ-008**

The noise development of the VHZ-008... at 2 l/min is < 50 dB

**VHZ-010**

The noise development of the VHZ-010... at 6 l/min is < 50 dB

**VHZ-025**

The noise development of the VHZ-025... at 150 l/min is < 70 dB

**VHZ-020**

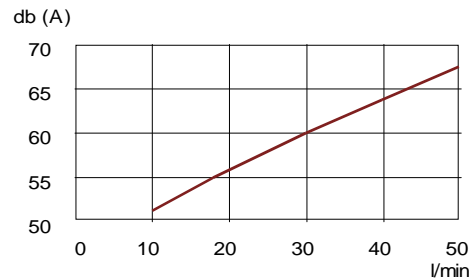

The noise level always remains below the curve with the specified flow value. Test viscosity was 22 mm<sup>2</sup>/s. With a higher viscosity the noise level is lower.

**Combinations**

Due to the high conformity of the gear measurement, the sensor electronics can be replaced arbitrarily. This makes it easier simply change the electronics if necessary or desired (exception: VHZ-08).



**Product Information**

**Sensors and Instrumentation**

**On the spot programming options**

**Comments**

**LABO-VHZ-I/U/F/C/S**



Pulse programming on pin 2:  
Apply the supply voltage level for one second and save the current value as the final value (for analog outputs) or as a switching value (for limit value switches).

Filters of 30 µm mesh size should be used.  
If there is a possibility of ferritic abrasion, magnetic filters should be installed in the line upstream of the transmitter.

Installation downstream of a rapidly switching valve should be avoided because of the possible pulses in flow rate. Always install measuring equipment on the pressure side.

Gently starting pumps protect your instruments and pipe installations.

**FLEX-VHZ**



Programming with magnet clip:  
Hold the magnet to the marking for 1 second and save the present value as the final value (for analog outputs) or as a switching value (for limit value switches).

**OMNI-VHZ**











Programming with magnet ring:  
With the aid of the display and of the movable ring, numerous parameters can be conveniently set on the spot.

**ECI-1**



If required, all parameters can be set at any time on all intelligent sensors, using the ECI-1 device configurator.

## Device overview

Device	Range	Pressure resistance	Medium temperature	Supply voltage	Display	Output signal		Page
						Switching	Measuring	
<b>VHZ</b> 	0.02..150 l/min	PN 100..200	-25..+80 °C (150 °C)	10..30 V DC	For option plug M12x1 Signal LED	-	Pulse / volume (Push-Pull)	<b>6</b>
<b>LABO-VHZ-S</b> 	0.02..150 l/min	PN 100..200	-25..+80 °C (150 °C)	10..30 V DC	Signal LED	1 x Push- Pull	-	<b>10</b>
<b>LABO-VHZ-I</b> 	0.02..150 l/min	PN 100..200	-25..+80 °C (150 °C)	10..30 V DC	Signal LED	-	4..20 mA	<b>15</b>
<b>LABO-VHZ-U</b> 	0.02..150 l/min	PN 100..200	-25..+80 °C (150 °C)	15..30 V DC	Signal LED	-	0..10 V	<b>15</b>
<b>LABO-VHZ-F</b> 	0.02..150 l/min	PN 100..200	-25..+80 °C (150 °C)	10..30 V DC	Signal LED	-	Programmable F / F trans- ducer 0..2 kHz Push-Pull	<b>15</b>
<b>LABO-VHZ-C</b> 	0.02..150 l/min	PN 100..200	-25..+80 °C (150 °C)	10..30 V DC	Signal LED	-	1 pulse per defined quantity, push- pull	<b>15</b>
<b>FLEX-VHZ</b> 	0.02..150 l/min	PN 100..200	-25..+80 °C (150 °C)	18..30 V DC	Signal LED	1 x Push- Pull	0/4..20 mA oder 0..10 V or frequency 0..2 kHz	<b>19</b>
<b>OMNI-VHZ</b> 	0.02..150 l/min	PN 100..200	-25..+80 °C (150 °C)	18..30 V DC	Graphic LCD illuminated transflective and signal LED	2 x Push- Pull	0/4..20 mA oder 0..10 V	<b>24</b>
<b>OMNI-C-VHZ (counter)</b> 	Totaliser / consumption counter from one increment to 9999m <sup>3</sup>	PN 100..200	-25..+80 °C (150 °C)	18..30 V DC	Graphic LCD illuminated transflective and signal LED	2 x Push- Pull	-	<b>29</b>
<b>ECI-1</b>	All LABO, FLEX, and OMNI parameters can be set or modified using the ECI-1 configurator.							<b>34</b>
<b>Options</b>	<ul style="list-style-type: none"> <li>● LABO transmitter – Temperature up to 150 °</li> <li>● OMNI – Tropical model</li> </ul>							<b>35</b>
<b>Accessories</b>	<ul style="list-style-type: none"> <li>● Type ZV / ZE (Filter)</li> <li>● KB... (Round plug connector 4/5-pin)</li> <li>● OMNI-TA (Panel meter)</li> <li>● OMNI-C-TA (Panel counter)</li> <li>● OMNI-remote</li> <li>● EEZ-904 (External universal counter)</li> </ul>							<b>36</b>

Errors and technical modifications reserved.

## Flow Transmitter VHZ



- Ideally suited for viscous media (oils)
- Light and compact construction in an aluminium housing
- For cost-sensitive applications

### Characteristics

The VHZ gearwheel flow meter measures the flow by a volumetric principle, in which a pair of gearwheels is moved proportional to the flow rate. The movement of the gearwheels is measured through the enclosing housing wall by a sensor. The devices are suitable for viscous, fluid, self-lubricating media, as well as for aqueous fluids such as soaps, pasts, emulsions etc. which have a non-abrasive character. Because of the volumetric functioning principle, the devices are almost completely independent of viscosity.

A push-pull transistor output, an A / B output or a two wire output are available as signal output.

The push-pull output can as desired be connected as a PNP or an NPN output, and emits a frequency proportional to the flow rate.

The A / B output consists of two push-pull outputs, whose signals are phase-shifted by 90 °. This makes it possible to determine the direction of flow using the bidirectionally driven sensor. The 2 wire model represents the pulse as two different currents, and has the advantage of reduced wiring effort.

Alternatively, it is possible to use add-on electronics with signal processing, in the series OMNI, FLEX and LABO.

### Technical data

<b>Sensor</b>	gearwheel volumeter	
<b>Nominal width</b>	DN 8..25	
<b>Process connection</b>	female thread G 1/4..G 1	
<b>Metering ranges</b>	0.02..150 l/min for details, see table "Ranges"	
<b>Measurement accuracy</b>	±3 % of the measured value in the specified metering range (measured at 20 mm <sup>2</sup> /s)	
<b>Repeatability</b>	±0,3 %	
<b>Medium temperature</b>	-25..+80 °C optionally -25..+120 °C (2-wire model DN 10-25)	
<b>Ambient temperature</b>	-20..+70 °C	
<b>Pressure resistance</b>	see table "Pressure resistance and Weight"	
<b>Pressure loss</b>	see upstream page "Function and benefits - volumetric, gearwheel"	
<b>Materials medium-contact</b>	see table "Materials"	
<b>3 wire or A / B-output</b>	<b>Supply voltage</b>	10..30 V DC
	<b>Current consumption</b>	approx. 20 mA without load
	<b>Signal output</b>	transistor output "push-pull" (resistant to short circuits and polarity reversal) I <sub>out</sub> = 100 mA max.
<b>2 wire</b>	<b>Supply voltage</b>	4.5..24 V DC
	<b>Signal output</b>	Low: 7 mA High: 14 mA
	<b>Reversed polarity protected</b>	yes
<b>Electrical connection</b>	optional plug DIN 43650-A / ISO 4400 or for round plug connector M12x1, 4-pole	
<b>Ingress protection</b>	IP 65	
<b>Weight</b>	see table "Pressure resistance and weight"	
<b>Conformity</b>	CE	

### Pressure resistance and weight

G	Types	PN	Housing material	Weight kg
G 1/4	VHZ-008GA	200	Aluminium	0.5
G 1/4	VHZ-008GK	160	Stainless steel	1.5
G 3/8	VHZ-010GA	200	Aluminium	0.5
G 3/8	VHZ-010GK	200	Stainless steel	1.5
G 3/4	VHZ-020GA	200	Aluminium	1.6
G 3/4	VHZO-020GA	100	Aluminium / glass	1.6
G 1	VHZ-025GA	100	Aluminium	6.3

**Product Information**

**Sensors and Instrumentation**

**Ranges**

Metering range	Types	Pulse volume	Frequency
l/min		cm <sup>3</sup>	Hz at Q <sub>max</sub>
0.02.. 2	VHZ-008	0.04	833
0.10.. 6	VHZ-010	0.20	500
0.50.. 50	VHZ(O)-020	2.00	417
3.00.. 150	VHZ-025	5.22	479

**Materials**

	VHZ-008..025GA	VHZ-008GK	VHZ-010..025GK
<b>Housing</b>	Al anodised	stainless steel 1.4404	stainless steel 1.4404
<b>gear-wheel and Axis</b>	stainless steel 1.4462	stainless steel 1.4462	stainless steel 1.4462
<b>Bearing</b>	Iglidur X	stainless steel 1.4037 / 1.4016 /P VD-coated	Iglidur X
<b>Seal</b>	FKM	FKM	FKM
<b>Sight glass</b>	Glass (only with VHZO)		

**Wiring**

Before the electrical installation, it must be ensured that the supply voltage complies with the data sheet. The use of shielded cabling is recommended.

**Push-pull output**

with round plug connector M12x1

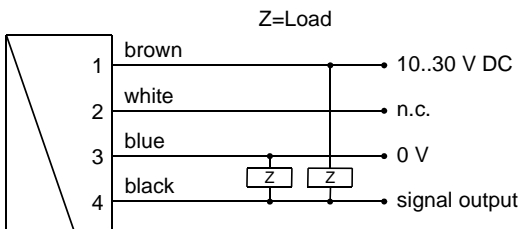

Connection example: PNP NPN

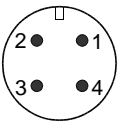

with plug as per DIN 43650-A / ISO 4400

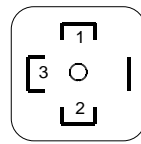
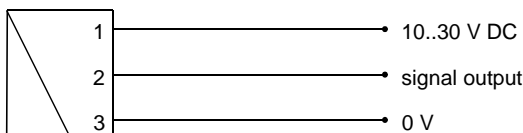

**A / B output**

only with 4-pole round plug connector

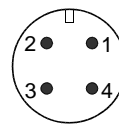
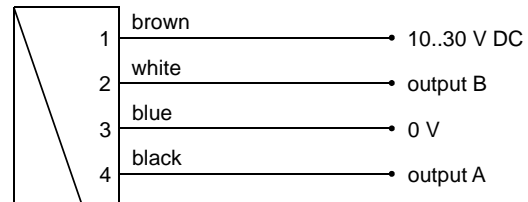

**2 wire model**

with plug as per DIN 43650-A / ISO 4400

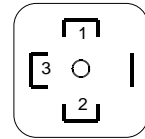
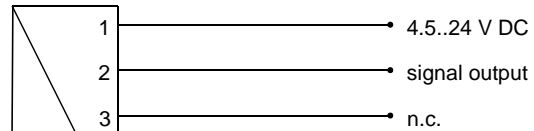

with round plug connector M12x1

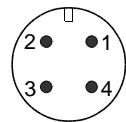
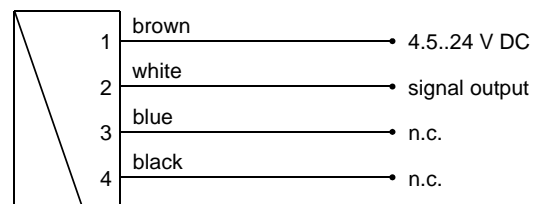

**Product Information**

**Sensors and Instrumentation**

**Dimensions**

**VHZ-008**

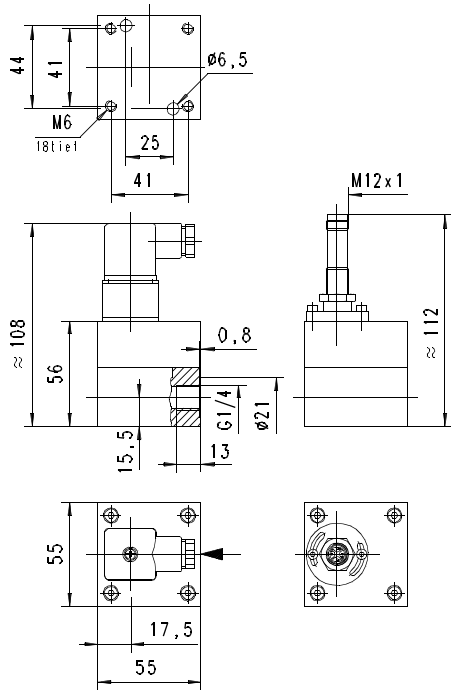

**VHZ-020**

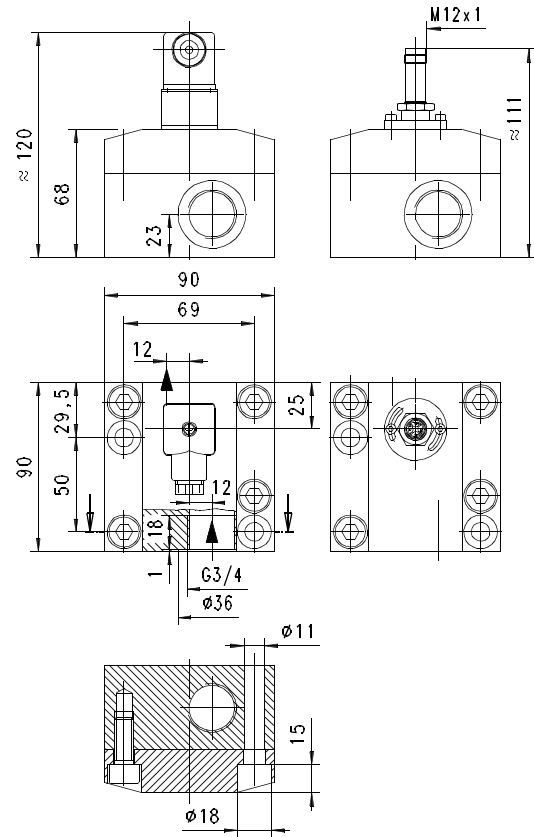

**VHZ-010**

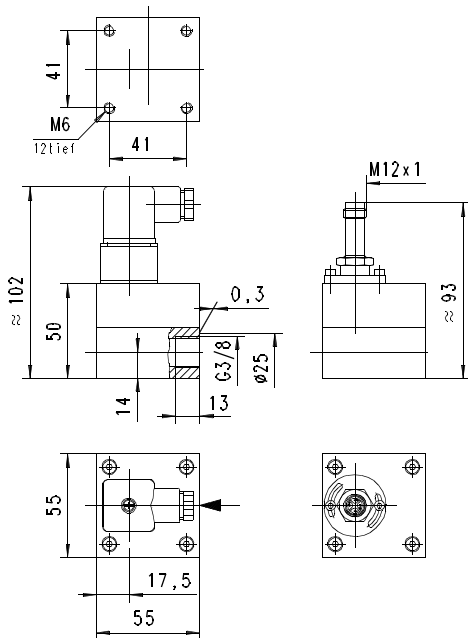

**VHZ-025**

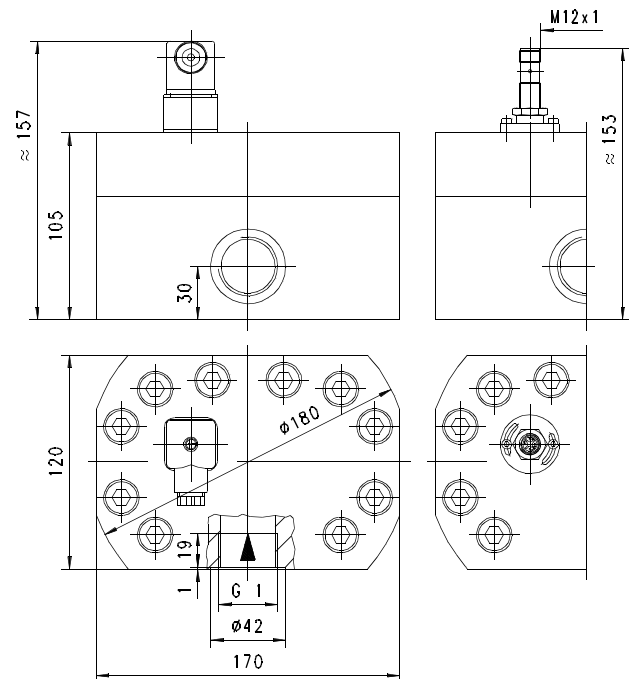



**Product Information**

**Handling and Operation**

**Installation**

The VHZ flow measurement device can be installed anywhere in the pipework system. A run-in section is not required. The direction of flow may be freely chosen. It should be ensured that no dirt particles (thread cutting swarf!) can get into the flow space, as this could cause the blockage of the gearwheels. It may therefore be necessary to install filters upstream of the flow measurement device (mesh size 30 µm).

**Ordering code**

VHZ-  1.  2.  3. **G** 4.  5.  6.  7.

○=Option

<b>1. Sight glass</b>							
-	no sight glass						
○	with sight glass						
<b>2. Nominal width</b>							
008	DN 8 - G 1/4						●
010	DN 10 - G 3/8						●
020	DN 20 - G 3/4						● ●
025	DN 25 - G 1						●
<b>3. Process connection</b>							
G	female thread						
<b>4. Body material</b>							
A	aluminium		●	●	●	●	
K	○ stainless steel						● ●
<b>5. Ranges</b>							
002	0.02.. 2 l/min						●
006	0.10.. 6 l/min						●
050	0.50.. 50 l/min					●	
150	3.00..150 l/min		●				
<b>6. Signal output</b>							
M	push-pull transistor output						
A	○ A / B output (2 x push-pull)						
Z	○ 2 wire						
<b>7. Electrical connection</b>							
B	plug DIN 43650A / ISO 4400						
S	○ for round plug connector M12x1, 4-pole						

Attention: The A / B output requires the use of a 4-pole round plug connector!

**Options**

- Highest temperature 120 °C

**Accessories**

- Cable/round plug connector (KB...) see additional information "Accessories"
- Remote flow display OMNI-TA
- Totaliser OMNI-C-TA
- Universal panel mount counter EEZ-904

# Flow Switch LABO-VHZ-S



- Volumetric flow switching
- Almost no effect from differing viscosities
- Versatile, configurable switching output in push-pull design
- Robust construction
- Compact design

## Characteristics

The VHZ gearwheel flow meter measures the flow by a volumetric principle, in which a pair of gearwheels is moved proportional to the flow rate. The movement of the gearwheels is measured through the enclosing housing wall by a sensor. The devices are suitable for viscous, fluid, self-lubricating media, as well as for aqueous fluids such as soaps, pasts, emulsions etc. which have a non-abrasive character. Because of the volumetric functioning principle, the devices are almost completely independent of viscosity.

The LABO electronics fitted to the device make available an electronic switching output (push-pull) with adjustable characteristics (minimum/maximum) and hysteresis, which responds when an adjustable limit is fallen short of or exceeded.

If desired, the switching value can be set to the currently existing flow using "teaching". Models with analog or pulse output are also available (see separate data sheets).

## Technical data

<b>Sensor</b>	gearwheel volumeter	
<b>Nominal width</b>	DN 8..25	
<b>Process connection</b>	female thread G 1/4..G 1	
<b>Switching ranges</b>	0.02..150 l/min for details, see table "Ranges"	
<b>Measurement accuracy</b>	±3 % of the measured value in the specified metering range (measured at 20 mm <sup>2</sup> /s)	
<b>Repeatability</b>	±0,3 %	
<b>Medium temperature</b>	-25..+80 °C optionally -25..+120 °C	
<b>Ambient temperature</b>	-20..+70 °C	
<b>Pressure resistance</b>	see table "Pressure resistance and weight"	
<b>Pressure loss</b>	see upstream page "Function and benefits - volumetric, gearwheel"	
<b>Materials medium-contact</b>	see table "Materials"	
<b>Materials, non-medium-contact</b>	Sensor tube	CW614N nickelled
	Adhesive	Epoxy resin
	Flange bolts	stainless steel
<b>Supply voltage</b>	10..30 V DC	
<b>Power consumption</b>	< 1 W (for no-load output)	
<b>Switching output</b>	transistor output "push-pull" (resistant to short circuits and polarity reversal) I <sub>out</sub> = 100 mA max.	
<b>Display</b>	yellow LED (On = Normal / Off = Alarm / rapid flashing = Programming)	
<b>Electrical connection</b>	for round plug connector M12x1, 4-pole	
<b>Ingress protection</b>	IP 67	
<b>Weight</b>	see table "Pressure resistance and weight"	
<b>Conformity</b>	CE	

## Pressure resistance and weight

G	Types	PN	Housing material	Weight kg
G 1/4	LABO-VHZ-008GA	200	Aluminium	0.5
G 1/4	LABO-VHZ-008GK	160	stainless steel	1.5
G 3/8	LABO-VHZ-010GA	200	Aluminium	0.5
G 3/8	LABO-VHZ-010GK	200	stainless steel	1.5
G 3/4	LABO-VHZ-020GA	200	Aluminium	1.6
G 3/4	LABO-VHZO-020GA	100	Aluminium / glass	1.6
G 1	LABO-VHZ-025GA	100	Aluminium	6.3

## Ranges

Metering range l/min	Types	Pulse volume (= resolution) cm <sup>3</sup>
0.02.. 2	LABO-VHZ-008	0.04
0.10.. 6	LABO-VHZ-010	0.20
0.50.. 50	LABO-VHZ(O)-020	2.00
3.00.. 50	LABO-VHZ-025	5.22

**Product Information**

**Sensors and Instrumentation**

**Materials**

	LABO-VHZ-008..025GA	LABO-VHZ-008GK	LABO-VHZ-010..025GK
<b>Housing</b>	Al anodised	stainless steel 1.4404	stainless steel 1.4404
<b>gearwheel and Axis</b>	stainless steel 1.4462	stainless steel 1.4462	stainless steel 1.4462
<b>Bearing</b>	Iglidur X	stainless steel 1.4037 / 1.4016 /PVD-coated	Iglidur X
<b>Seal</b>	FKM	FKM	FKM
<b>Sight glass</b>	glass (only with VHZO)		

**Dimensions**

**LABO-VHZ-008**

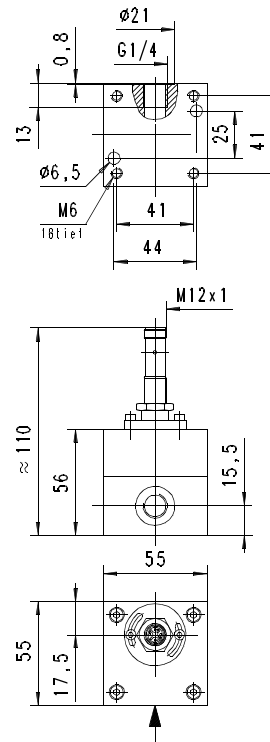

**Wiring**

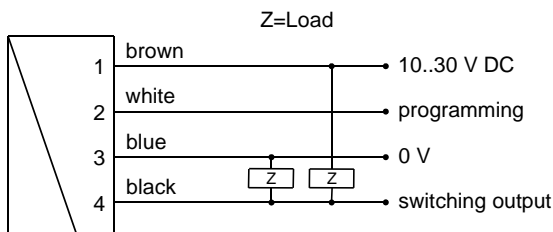

Connection example: PNP NPN

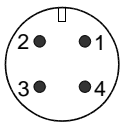

Before the electrical installation, it must be ensured that the supply voltage corresponds to the data sheet. It is recommended to use shielded wiring.

**LABO-VHZ-010**

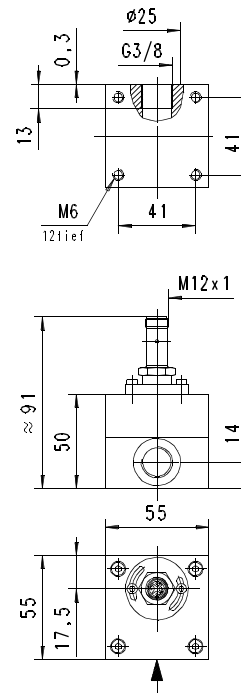

**Product Information**

**Sensors and Instrumentation**

**LABO-VHZ-020**

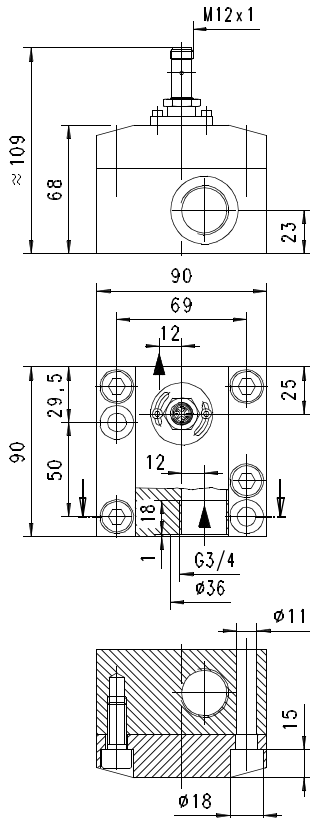

**LABO-VHZ-025**

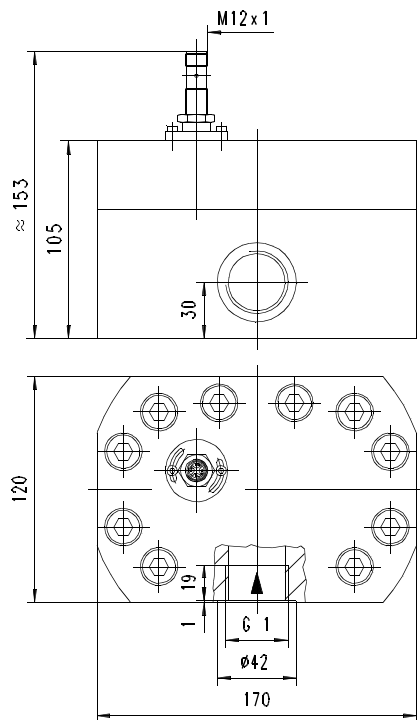

**Handling and operation**

**Installation**

The VHZ flow measurement device can be installed anywhere in the pipework system. A run-in section is not required. The direction of flow may be freely chosen.

It should be ensured that no dirt particles (thread cutting swarf) can get into the flow space, as this could cause the blockage of the gearwheels. It may therefore be necessary to install filters upstream of the flow measurement device (mesh size 30 µm).

**Note**

The switching value can be programmed by the user via "teaching". If desired, programmability can be blocked by the manufacturer.

The ECI-1 device configurator with associated software is available as a convenient option for programming all parameters by PC, and for adjustment.

**Operation and programming**

The switching value is set as follows:

- Apply the flow rate to be set to the device.
- Apply an impulse of at least 0.5 seconds and max. 2 seconds duration to pin 2 (e.g. via a bridge to the supply voltage or a pulse from the PLC), in order to accept the measured value.
- When the teaching is complete, pin 2 should be connected to 0 V, so as to prevent unintended programming.

The device has a yellow LED which flashes during the programming pulse. During operation, the LED serves as a status display for the switching output.

In order to avoid the need to transit to an undesired operating status during the teach-in, the device can be provided ex-works with a teach-offset. The teach-offset point is added to the currently measured value before saving. The offset point can be positive or negative.

*Example: The switching value should be set to 80 l/min. However, it is possible only to reach 60 l/min without problems. In this case, the device would be set using a teach-offset of +20 l/min. At a flow rate of 60 l/min in the process, teaching would then store a value of 80 l/min.*

The limit switch can be used to monitor minima or maxima.

With a minimum-switch, falling below the limit value causes a switchover to the alarm state. Return to the normal state occurs when the limit value plus the set hysteresis is once more exceeded.

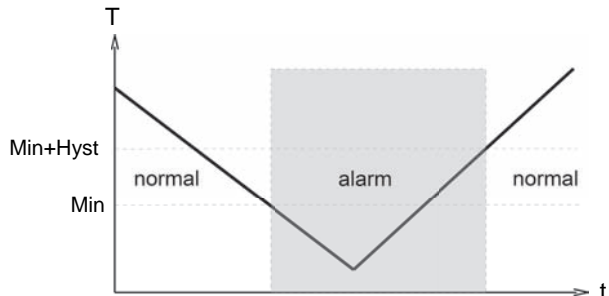

**Product Information**

With a maximum-switch, exceeding the limit value causes a switchover to the alarm state. Return to the normal state occurs when the measured value once more falls below the limit value minus the set hysteresis.

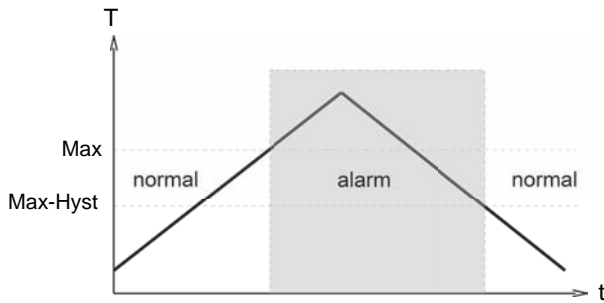

A switchover delay time ( $t_{DS}$ ) can be applied to the switchover to the alarm state. Equally, one switch-back delay time ( $t_{DR}$ ) of several can

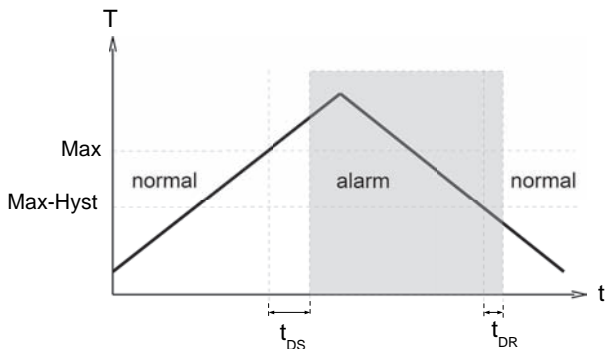

be applied to switching back to the normal state. In the normal state the integrated LED is on, in the alarm state it is off, and this corresponds to its status when there is no supply voltage.

In the non-inverted (standard) model, while in the normal state the switching output is at the level of the supply voltage; in the alarm state it is at 0 V, so that a wire break would also display as an alarm state at the signal receiver. Optionally, an inverted switching output can also be provided, i.e. in the normal state the output is at 0 V, and in the alarm state it is at the level of the supply voltage.

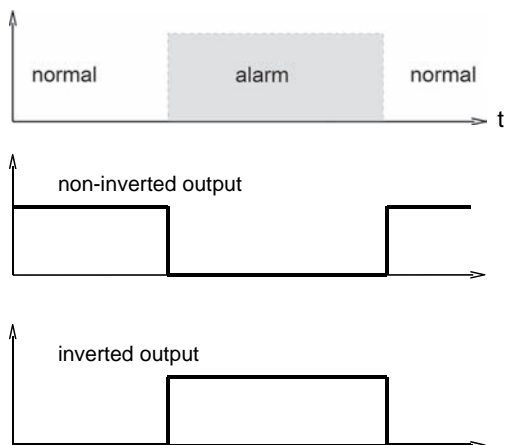

A Power-On-Delay function (ordered as a separate option) makes it possible to maintain the switching output in the normal state for a defined period after application of the supply voltage.

**Ordering code**

The base device is ordered, e.g. VHZ-008GA002E with electronics, e.g. OMNI-VHZ-008IPLO

VHZ-         
 LABO-VHZ-

○=Option

<b>1. Sight glass</b>												
-	no sight glass											
O-	with sight glass											
<b>2. Nominal width</b>												
008	DN 8 - G 1/4											
010	DN 10 - G 3/8											
020	DN 20 - G 3/4											
025	DN 25 - G 1											
<b>3. Process connection</b>												
G	female thread											
<b>4. Body material</b>												
A	aluminium											
K	○ stainless steel											
<b>5. Ranges</b>												
002	0.02.. 2 l/min											
006	0.10.. 6 l/min											
050	0.50.. 50 l/min											
150	3.00..150 l/min											
<b>6. Connection for</b>												
E	electronics											
<b>7. For base device</b>												
008	VHZ-008G....E											
010	VHZ-010G....E											
020	VHZ(O)-020G....E											
025	VHZ-025G....E											
<b>8. Switching output</b>												
S	push-pull (compatible with PNP and NPN)											
<b>9. Programming</b>												
N	cannot be programmed (no teaching)											
P	○ programmable (teaching possible)											
<b>10. Switching function</b>												
L	minimum-switch											
H	maximum-switch											
<b>11. Switching signal</b>												
O	standard											
I	○ inverted											
<b>12. Electrical connection</b>												
S	for round plug connector M12x1, 4-pole											
<b>13. Option</b>												
H	○ medium temperature max. 120 °C (with 300 mm cable)											

**Product Information**

**Sensors and Instrumentation**

**Options**

**Switching delay period** (0.0..99.9 s) . s  
(from Normal to Alarm)

**Switch-back delay period** (0.0..99.9 s) . s  
(from Alarm to Normal)

**Power-On delay period** (0..99 s)  s  
(after connecting the supply, time during which the outputs are not actuated)

**Switching output fixed at**  l/min

**Switching hysteresis**  %  
standard = 2 % of the metering range

**Teach-offset**  %  
(in percent of the metering range)  
standard = 0 %

Further options available on request.

**Accessories**

- Cable/round plug connector (KB...) see additional information "Accessories"
- Device configurator ECI-1

# Flow Transmitter LABO-VHZ-I / U / F / C



- Volumetric flow measurement
- Almost no effect from differing viscosities
- 0..10 V, 4..20 mA, frequency/pulse output, completely configurable
- Robust construction
- Compact design

## Characteristics

The VHZ gearwheel flow meter measures the flow by a volumetric principle, in which a pair of gearwheels is moved proportional to the flow rate. The movement of the gearwheels is measured through the enclosing housing wall by a sensor. The devices are suitable for viscous, fluid, self-lubricating media, as well as for aqueous fluids such as soaps, pasts, emulsions etc. which have a non-abrasive character. Because of the volumetric functioning principle, the devices are almost completely independent of viscosity.

The LABO electronics make various output signals available:

- Analog signal 0/4..20 mA (LABO-VHZ-...I)
- Analog signal 0/2..10 V (LABO-VHZ-...U)
- Frequency signal (LABO-VHZ-...F) or
- A value signal Pulse / x Litres (LABO-VHZ-...C)

A model with switching output is also available.

If desired, the range end value can be set to the currently existing flow using "teaching".

## Technical data

<b>Sensor</b>	gearwheel volumeter	
<b>Nominal width</b>	DN 8..25	
<b>Process connection</b>	female thread G 1/4..G 1	
<b>Metering ranges</b>	0.02..150 l/min for details, see table "Ranges"	
<b>Measurement accuracy</b>	±3 % of the measured value in the specified metering range (measured at 20 mm <sup>2</sup> /s)	
<b>Repeatability</b>	±0.3 %	
<b>Medium temperature</b>	-25..+80 °C optionally -25..+120 °C	
<b>Ambient temperature</b>	-20..+70 °C	
<b>Pressure resistance</b>	see table "Pressure resistance and weight"	
<b>Pressure loss</b>	see upstream page "Function and benefits - volumetric, gearwheel"	
<b>Materials medium-contact</b>	see table "Materials"	
<b>Materials, non-medium-contact</b>	Sensor tube	CW614N nickelled
	Adhesive	Epoxy resin
	Flange bolts	stainless steel
<b>Supply voltage</b>	10..30 V DC at voltage output 10 V: 15..30 V DC	
<b>Power consumption</b>	< 1 W (for no-load outputs)	
<b>Output data:</b>	all outputs are resistant to short circuits and reversal polarity protected	
Current output:	4..20 mA (0..20 mA available on request)	
Voltage output:	0..10 V (2..10 V available on request)	
Frequency output:	output current max. 20 mA transistor output "push-pull"	
Pulse output:	I <sub>out</sub> = 100 mA max. transistor output "push-pull"	
	I <sub>out</sub> = 100 mA max. pulse width 50 ms pulse per volume is to be stated	
<b>Display</b>	yellow LED indicates operating voltage (LABO-VHZ-I / U) or output status (LABO-VHZ-F / C) (rapid flashing = Programming)	
<b>Electrical connection</b>	for round plug connector M12x1, 4-pole	
<b>Ingress protection</b>	IP 67	
<b>Weight</b>	see table "Connection, pressure resistance, and weight"	
<b>Conformity</b>	CE	

## Pressure resistance and weight

G	Types	PN	Housing material	Weight kg
G 1/4	LABO-VHZ-008GA	200	Aluminium	0.5
G 1/4	LABO-VHZ-008GK	160	Stainless steel	1.5
G 3/8	LABO-VHZ-010GA	200	Aluminium	0.5
G 3/8	LABO-VHZ-010GK	200	Stainless steel	1.5
G 3/4	LABO-VHZ-020GA	200	Aluminium	1.6
G 3/4	LABO-VHZO-020GA	100	Aluminium / glass	1.6
G 1	LABO-VHZ-025GA	100	Aluminium	6.3

**Product Information**

**Sensors and Instrumentation**

**Ranges**

Metering range l/min	Types	Pulse volume (= resolution) cm <sup>3</sup>
0.02.. 2	LABO-VHZ-008	0.04
0.10.. 6	LABO-VHZ-010	0.20
0.50.. 50	LABO-VHZ(O)-020	2.00
3.00.. 150	LABO-VHZ-025	5.22

**Materials**

	LABO-VHZ-008..025GA	LABO-VHZ-008GK	LABO-VHZ-010..025GK
<b>Housing</b>	Al anodised	stainless steel 1.4404	stainless steel 1.4404
<b>gear-wheel and Axis Bearing</b>	stainless steel 1.4462	stainless steel 1.4462	stainless steel 1.4462
<b>Seal</b>	FKM	stainless steel 1.4037 / 1.4016 /PVD-coated	iglidur X
<b>Sight glass</b>	glass (only with VHZO)	FKM	FKM

**Wiring**

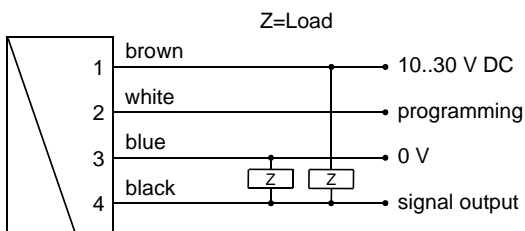

Connection example: PNP NPN

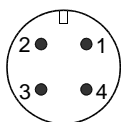

Before the electrical installation, it must be ensured that the supply voltage corresponds to the data sheet.

It is recommended to use shielded wiring.

The push-pull output) of the frequency or pulse output version can as desired be switched as a PNP or an NPN output.

**Dimensions**

**LABO-VHZ-008**

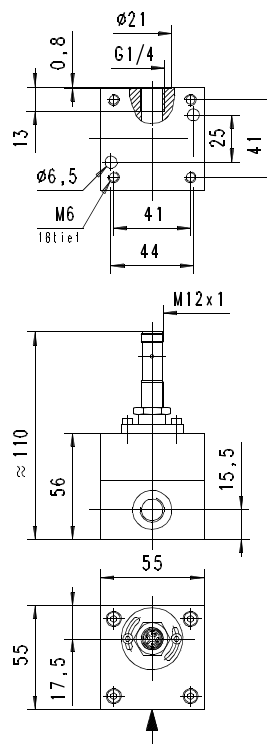

**LABO-VHZ-010**

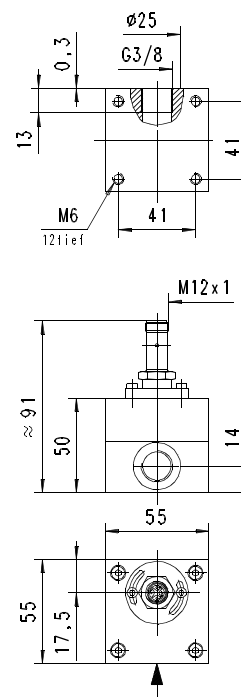



**Product Information**

**Sensors and Instrumentation**

**LABO-VHZ-020**

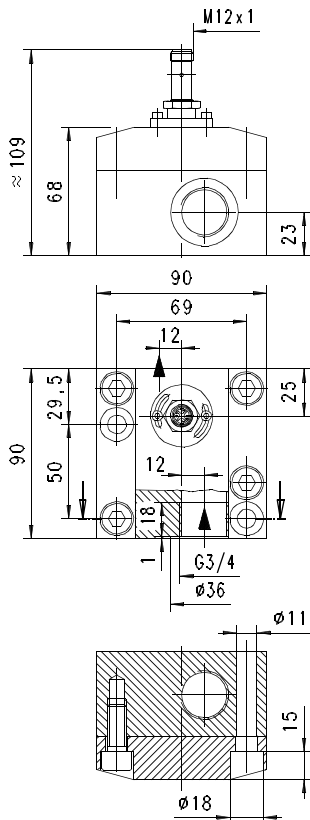

**LABO-VHZ-025**

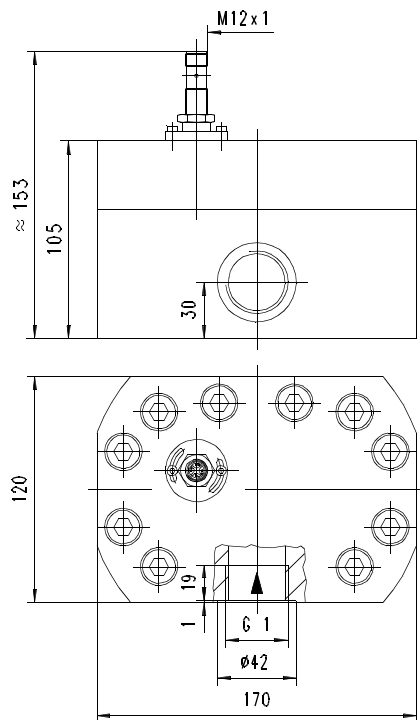

**Handling and operation**

**Installation**

The VHZ flow measurement device can be installed anywhere in the pipework system. A run-in section is not required. The direction of flow may be freely chosen.

It should be ensured that no dirt particles (thread cutting swarf) can get into the flow space, as this could cause the blockage of the gearwheels. It may therefore be necessary to install filters upstream of the flow measurement device (mesh size 30 µm).

**Note**

The metering range end value can be programmed by the user via "teaching". Requirement for programmability must be stated when ordering, otherwise the device cannot be programmed. The ECI-1 device configurator with associated software is available as a convenient option for programming all parameters by PC, and for adjustment.

The teaching option is not available for the pulse output version.

**Operation and programming**

The teaching process can be carried out by the user as follows:

- The flow rate to be set is applied to the device.
- Apply an impulse of at least 0.5 seconds and max. 2 seconds duration to pin 2 (e.g. via a bridge to the supply voltage or a pulse from the PLC), in order to accept the measured value.
- When the teaching is complete, pin 2 should be connected to 0 V, so as to prevent unintended programming.

The devices have a yellow LED which flashes during the programming pulse. During operation, the LED serves as an indicator of operating voltage (for analog output) or of switching status (for frequency or pulse output).

In order to avoid the need to transit to an undesired operating status during the teach-in, the device can be provided ex-works with a teach-offset. The teach-offset point is added to the currently measured value before saving. The offset point can be positive or negative.

*Example: The end of the metering range should be set to 80 %. However, only 60 % can be achieved without problem. In this case, the device would be ordered with a "teach-offset" of +20 %.. At a flow rate of 60 % in the process, teaching would then store a value of 80 %.*

There are many more parameters which can be programmed by the ECI-1 device configurator if necessary.

**Product Information**

**Sensors and Instrumentation**

**Ordering code**

The base device is ordered, e.g. VHZ-008GA002E with electronics, e.g. OMNI-VHZ-008IPLO

1. 2. 3. 4. 5. 6.  
**VHZ-**   **G**   **E**

7. 8. 9. 10. 11.  
**LABO-VHZ-**    **S**

○=Option

<b>1. Sight glass</b>					
-	no sight glass				
O-	with sight glass				
<b>2. Nominal width</b>					
008	DN 8 - G 1/4				•
010	DN 10 - G 3/8				•
020	DN 20 - G 3/4				•
025	DN 25 - G 1				•
<b>3. Process connection</b>					
G	female thread				
<b>4. Body material</b>					
A	aluminium		•	•	•
K	○ stainless steel				•
<b>5. Ranges</b>					
002	0.02.. 2 l/min				•
006	0.10.. 6 l/min				•
050	0.50.. 50 l/min			•	
150	3.00..150 l/min		•		
<b>6. Connection for</b>					
E	electronics		•	•	•
<b>7. For base device</b>					
008	VHZ-008G..E				•
010	VHZ-010G..E				•
020	VHZ(O)-020G..E			•	
025	VHZ-025G..E		•		
<b>8. Signal output</b>					
I	current output 4..20 mA				
U	voltage output 0..10 V				
F	frequency output				
C	pulse output				
<b>9. Programming</b>					
N	cannot be programmed (no teaching)				
P	○ programmable (teaching possible)				
<b>10. Electrical connection</b>					
S	for round plug connector M12x1, 4-pole				
<b>11. Option</b>					
H	○ medium temperature max. 120 °C (with 300 mm cable)				

**Required ordering information**

**For LABO-VHZ-...F:**

**Output frequency at full scale**  Hz  
Maximum value: 2.000 Hz

**For LABO-VHZ-...C:**

The volume must be specified for the pulse output version (with numerical value and unit) which will correspond to one pulse.

**Volume per pulse (numerical value)**

**Volume per pulse (unit)**

**Options**

**Special range for analog output:**  l/min

<= metering range (standard=metering range)

**Special range for frequency output:**  l/min

<= metering range (standard=metering range)

**Power-On delay period (0..99 s)**  s

(time after applying power during which the outputs are not activated or set to defined values)

Further options available on request.

**Accessories**

- Cable/round plug connector (KB...) see additional information "Accessories"
- Evaluation electronics OMNI-TA
- Device configurator ECI-1

# Flow Transmitter / Switch FLEX-VHZ



- Analog output and switching output
- Designed for industrial use
- Small, compact construction
- Simple installation
- Simple to use
- Cable outlet infinitely rotatable

## Characteristics

The VHZ gearwheel flow meter measures the flow on the volumetric principle, in which a pair of gearwheels is moved proportional to the flow rate. The movement of the gearwheels is measured through the enclosing housing wall by a sensor. The devices are suitable for viscous, fluid, self-lubricating media, as well as for aqueous fluids such as soaps, pasts, emulsions etc. which have a non-abrasive character. Because of the volumetric functioning principle, the devices are almost completely independent of viscosity.

The FLEX transducer on the sensor has an analog output (4..20 mA or 0..10 V) and one switching output, which can be configured as a limit switch for monitoring minima or maxima, or as a frequency output. The switching output is designed as a push-pull driver, and can therefore be used both as a PNP or an NPN output. The state of the switching output is signalled with a yellow LED in the connection; the LED has all-round visibility.

The sensor is configured in the factory, or alternatively this can be done with the aid of the optionally available ECI-1 device configurator (USB interface for PC). A selectable parameter can be modified on the device, with the aid of the magnet clip provided. In this case, the current measured value is saved as the parameter value. Examples of these parameters are the switching value or the metering range end value.

The stainless steel electronics housing is rotatable, so it is possible to orient the cable outlet after installation.

## Technical data

<b>Sensor</b>	gearwheel volumeter
<b>Nominal width</b>	DN 8..25
<b>Process connection</b>	G 1/4..G 1
<b>Metering ranges</b>	0.02..150 l/min for details, see table "Ranges"
<b>Measurement accuracy</b>	±3 % of the measured value in the specified metering range (measured at 20 mm <sup>2</sup> /s)
<b>Repeatability</b>	±0.3 %
<b>Medium temperature</b>	-25..+80 °C, optionally -25..+120 °C
<b>Ambient temperature</b>	-20..+70 °C
<b>Materials medium-contact</b>	see table "Materials"
<b>Construction material</b>	stainless steel 1.4305
<b>Electronic housing</b>	Adapter: CW614N nickelled
<b>Pressure resistance</b>	PN 100..200 for details see table "Pressure resistance and weight"
<b>Pressure loss</b>	see upstream page "Function and benefits - volumetric, gearwheel"
<b>Supply voltage</b>	18..30 V DC
<b>Power consumption</b>	<1 W
<b>Analog output</b>	4..20 mA / load 500 Ohm max. or 0..10 V / load min. 1 kOhm
<b>Switching output</b>	transistor output "push-pull" (resistant to short circuits and polarity reversal) I <sub>out</sub> = 100 mA max.
<b>Switching hysteresis</b>	adjustable (please state when ordering) Standard setting: 2 % of full scale value, for Min-switch, position of the hysteresis above the limit value, and for Max-switch, below the limit value
<b>Display</b>	yellow LED (On = Normal / Off = Alarm)
<b>Electrical connection</b>	for round plug connector M12x1, 4-pole
<b>Ingress protection</b>	IP 65
<b>Weight</b>	see table "Pressure resistance and weight"
<b>Conformity</b>	CE

## Pressure resistance and weight

G	Types	PN	Housing material	Weight kg
G 1/4	FLEX-VHZ-008GA	200	Aluminium	0.65
G 1/4	FLEX-VHZ-008GK	160	Stainless steel	1.65
G 3/8	FLEX-VHZ-010GA	200	Aluminium	0.65
G 3/8	FLEX-VHZ-010GK	200	Stainless steel	1.65
G 3/4	FLEX-VHZ-020GA	200	Aluminium	1.75
G 3/4	FLEX-VHZO-020GA	100	Aluminium / glass	1.75
G 1	FLEX-VHZ-025GA	100	Aluminium	6.50

**Product Information**

**Sensors and Instrumentation**

**Ranges**

Metering range l/min	Types	Pulse volume (= resolution) cm <sup>3</sup>
0.02.. 2	FLEX-VHZ-008	0.04
0.10.. 6	FLEX-VHZ-010	0.20
0.50.. 50	FLEX-VHZ(O)-020	2.00
3.00.. 150	FLEX-VHZ-025	5.22

**Materials**

	FLEX-VHZ-008..025GA	FLEX-VHZ-008GK	FLEX-VHZ-010..025GK
<b>Housing</b>	Al anodised	stainless steel 1.4404	stainless steel 1.4404
<b>gearwheel and Axis</b>	stainless steel 1.4462	stainless steel 1.4462	stainless steel 1.4462
<b>Bearing</b>	Iglidur X	stainless steel 1.4037 / 1.4016 / PVD-coated	Iglidur X
<b>Seal</b>	FKM	FKM	FKM
<b>Sight glass</b>	glass (only with VHZO)		

**Wiring**

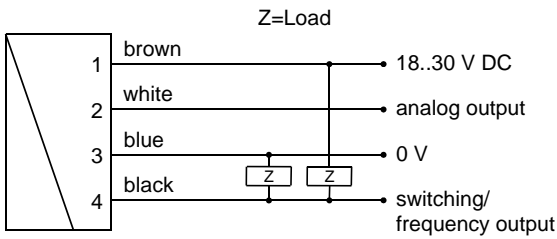

Connection example: PNP NPN

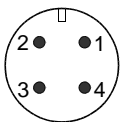

Before the electrical installation, it must be ensured that the supply voltage corresponds with the data sheet. It is recommended to use shielded wiring.

**Dimensions**

**FLEX-VHZ-008**

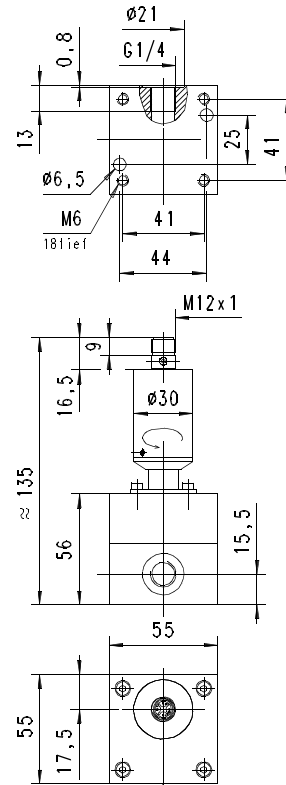

**FLEX-VHZ-010**

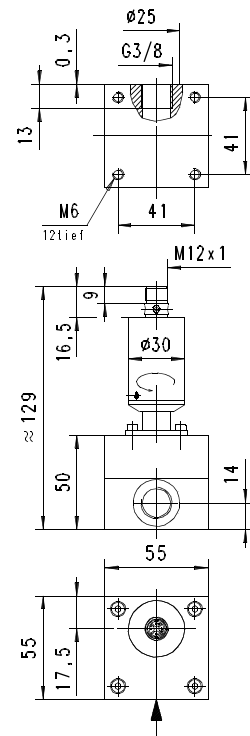

**Product Information**

**Sensors and Instrumentation**

**FLEX-VHZ-020**

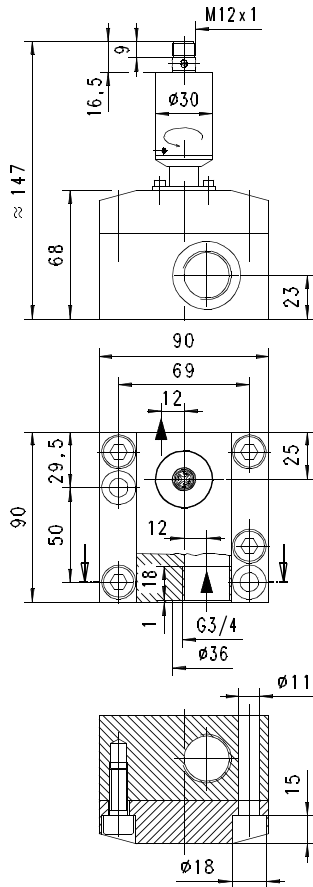

**FLEX-VHZ-025**

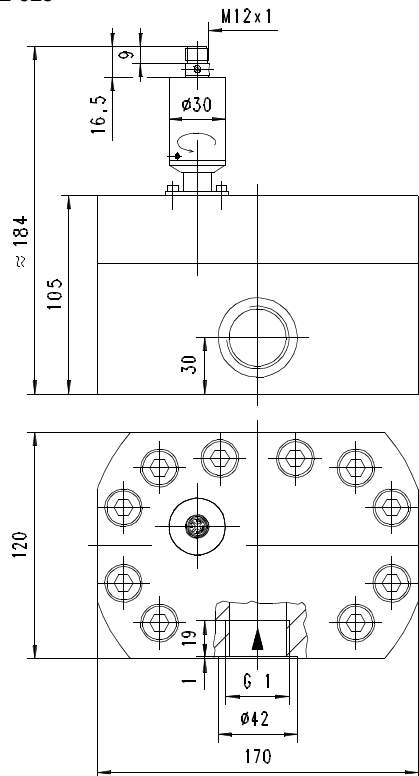

**Handling and operation**

**Installation**

The VHZ flow measurement device can be installed anywhere in the pipework system. A run-in section is not required. The direction of flow may be freely chosen.

It should be ensured that no dirt particles (thread cutting swarf) can get into the flow space, as this could cause the blockage of the gearwheels. It may therefore be necessary to install filters upstream of the flow measurement device (mesh size 30 µm).

**Programming**

The electronics contain a magnetic contact, with the aid of which different parameters can be programmed. Programming takes place when a magnet clip is applied for a period between 0.5 and 2 seconds to the marking located on the label. If the contact time is longer or shorter than this, no programming takes place (protection against external magnetic fields).



After the programming ("teaching"), the clip can either be left on the device, or removed to protect data.

The device has a yellow LED which flashes during the programming pulse. During operation, the LED serves as a status display for the switching output.

In order to avoid the need to transit to an undesired operating status during "teaching", the device can be provided ex-works with a "teach-offset". The "teach-offset" value is added to the currently measured value before saving (or is subtracted if a negative value is entered).

*Example: The switching value is to be set to 70 % of the metering range, because at this flow rate a critical process status is to be notified. However, only 50% can be achieved without danger. In this case, the device would be ordered with a "teach-offset" of +20 %. At 50 % in the process, a switching value of 70 % would then be stored during "teaching".*

Normally, programming is used to set the limit switch. However, if desired, other parameters such as the end value of the analog or frequency output may also be set.

**Product Information**

**Sensors and Instrumentation**

The limit switch can be used to monitor minima or maxima.

With a minimum-switch, falling below the limit value causes a switchover to the alarm state. Return to the normal state occurs when the limit value plus the set hysteresis is again exceeded.

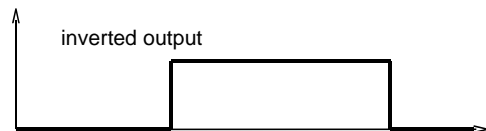
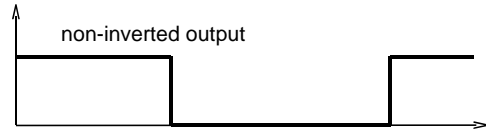
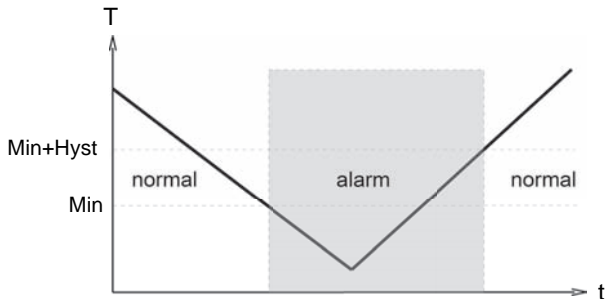

With a maximum-switch, exceeding the limit value causes a switchover to the alarm state. Return to the normal state occurs when the measured value once more falls below the limit value minus the set hysteresis.

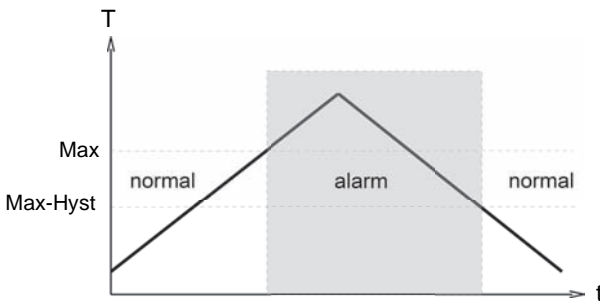

A Power-On delay function (ordered as a separate option) makes it possible to maintain the switching output in the normal state for a defined period after application of the supply voltage.

A switchover delay time ( $t_{DS}$ ) can be applied to the switchover to the alarm state. Equally, one switch-back delay time ( $t_{DR}$ ) of several can be applied to switching back to the normal state.

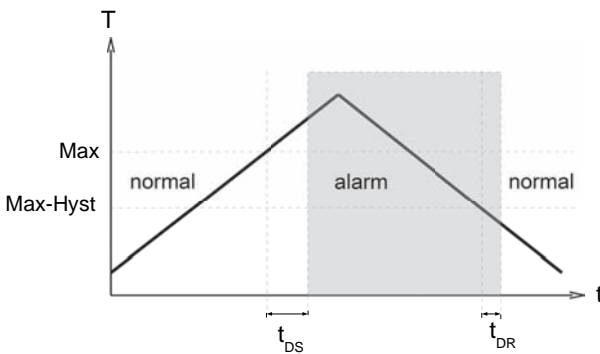

In the normal state the integrated LED is on, in the alarm state it is off, and this corresponds to its status when there is no supply voltage.

In the non-inverted (standard) model, while in the normal state the switching output is at the level of the supply voltage; in the alarm state it is at 0 V, so that a wire break would also display as an alarm state at the signal receiver. Optionally, an inverted switching output can also be provided, i.e. in the normal state the output is at 0 V, and in the alarm state it is at the level of the supply voltage.

**Product Information**

**Sensors and Instrumentation**

**Ordering code**

The base device is ordered, e.g. VHZ-008GA002E with electronics, e.g. FLEX-VHZ-008ILO

1. 2. 3. 4. 5. 6.  
VHZ

7. 8. 9. 10.  
FLEX-VHZ-

○=Option

<b>1. Sight glass</b>					
-	no sight glass				
O-	with sight glass				
<b>2. Nominal width</b>					
008	DN 8 - G 1/4				●
010	DN 10 - G 3/8				●
020	DN 20 - G 3/4				● ●
025	DN 25 - G 1				●
<b>3. Process connection</b>					
G	female thread				
<b>4. Body material</b>					
A	aluminium		●	●	●
K	○ stainless steel				● ●
<b>5. Ranges</b>					
002	0.02.. 2 l/min				●
006	0.10.. 6 l/min				●
050	0.50.. 50 l/min				●
150	3.00..150 l/min		●		
<b>6. Connection for</b>					
E	electronics		●	●	● ●
<b>7. For base device</b>					
008	VHZ-008G...E				●
010	VHZ-010G...E				●
020	VHZ(O)-020G...E				●
025	VHZ-025G...E		●		
<b>8. Analog output</b>					
I	current output 4..20 mA				
U	voltage output 0..10 V				
<b>9. Functioning of the switching output</b>					
L	minimum-switch				
H	maximum-switch				
R	frequency output				
<b>10. Switching signal</b>					
O	standard output				
I	inverted output				

**Options**

**Special range for analog output:**    l/min  
(not greater than the sensor's working range)

**Special range for frequency output:**    l/min  
(not greater than the sensor's working range)

**End frequency (max. 2000 Hz)**    Hz

**Switch-on delay** (from Alarm to OK)   s

**Switch-off-delay** (from OK to Alarm)   s

**Power-On delay (0..99 s)**   s  
(time after power on, during which the outputs are not actuated)

**Switching output fixed**    l/min

**Special hysteresis** (standard = 2 % EW)   %

**Gooseneck**   
(recommended at operating temperatures above 70 °C)

*If the fields are not completed, the standard setting is selected automatically.*

**Accessories**

- Cable/round plug connector (KB...) see additional information "Accessories"
- Device configurator ECI-1

**Product Information**

**Sensors and Instrumentation**

# Flow Transmitter / Switch OMNI-VHZ



- Flow sensor using the gearwheel principle
- Suitable for viscous media (oils, emulsions)
- Analog output 4..20 mA or 0..10 V
- Two programmable switches (push-pull)
- Graphical LCD display, backlit (transreflective), can be read in sunlight and in the dark
- Modifiable units in the display
- Programmable parameters via rotatable, removable ring (programming protection)
- Full metal housing with non-scratch, chemically resistant glass
- Rotatable electronic head for best reading position
- Small, compact construction
- Simple installation

## Characteristics

The VHZ gearwheel flow meter measures the flow by a volumetric principle, in which a pair of gearwheels is moved proportional to the flow rate. The movement of the gearwheels is measured through the enclosing housing wall by a sensor. The devices are suitable for viscous, fluid, self-lubricating media, as well as for aqueous fluids such as soaps, pasts, emulsions etc. which have a non-abrasive character. Because of the volumetric functioning principle, the devices are almost completely independent of viscosity.

The OMNI transducer located on the sensor has a backlit graphics LCD display which is very easy to read, both in the dark and in bright sunlight. The graphics display allows the presentation of measured values and parameters in a clearly understandable form.

The measured values are displayed to 4 places, together with their physical unit, which may also be modified by the user. The electronics have an analog output (4..20 mA or 0..10 V) and two switching outputs, which can be used as limit switches for monitoring minima or maxima, or as two-point controllers.

The switching outputs are designed as push-pull drivers, and can therefore be used both as PNP and NPN outputs. Exceeding limit values is signalled by a red LED which is visible over a long distance, and by a cleartext in the display. The stainless steel case has a hardened non-scratch mineral glass pane. It is operated by a programming ring fitted with a magnet, so there is no need to open the operating controls housing, and its leakproofness is permanently ensured.

By turning the ring to right or left, it is simple to modify the parameters (e.g. switching point, hysteresis...). To protect from unintended programming, it can be removed, turned through 180 ° and replaced, or completely removed, thus acting as a key.



## Technical data

<b>Sensor</b>	gearwheel volumeter	
<b>Nominal width</b>	DN 8..25	
<b>Process connection</b>	G 1/4..G 1	
<b>Metering ranges</b>	0.02..150 l/min for details, see table "Ranges"	
<b>Measurement accuracy</b>	±3 % of the measured value in the specified metering range (measured at 20 mm²/s)	
<b>Repeatability</b>	±0.3 %	
<b>Medium temperature</b>	-25..+80 °C optionally -25..+120 °C	
<b>Ambient temperature</b>	-20..+70 °C	
<b>Pressure resistance</b>	see table "Pressure resistance and weight"	
<b>Pressure loss</b>	see upstream page "Function and benefits - volumetric, gearwheel"	
<b>Materials medium-contact</b>	see table "Materials"	
<b>Materials non-medium-contact</b>	Electronic housing	stainless steel 1.4305
	Glass	mineral glass, hardened
	Magnet	Samarium-Cobalt
	Ring	POM
	Adapter	CW614N nickelled
<b>Supply voltage</b>	18..30 V DC	
<b>Power consumption</b>	< 1 W	
<b>Analog output</b>	4..20 mA / max. load 500 Ω or 0..10 V / min. load 1 kΩ	
<b>Switching outputs</b>	transistor output "push-pull" (resistant to short circuits and polarity reversal) I <sub>out</sub> = 100 mA max.	
<b>Hysteresis</b>	adjustable, position of the hysteresis depends on minimum or maximum	
<b>Display</b>	backlit graphical LCD-Display (transreflective), extended temperature range -20..+70 °C, 32 x 16 pixels, background illumination, displays value and unit, flashing LED signal lamp with simultaneous message on the display.	
<b>Electrical connection</b>	for round plug connector M12x1, 5-pole	
<b>Ingress protection</b>	IP 67 / (IP 68 when oil-filled)	
<b>Weight</b>	see table "Pressure resistance and weight"	
<b>Conformity</b>	CE	



**Product Information**

**Sensors and Instrumentation**

**Pressure resistance and weight**

G	Types	PN	Housing material	Weight kg
G 1/4	OMNI-VHZ-008GA	200	Aluminium	0.7
G 1/4	OMNI-VHZ-008GK	160	Stainless steel	1.7
G 3/8	OMNI-VHZ-010GA	200	Aluminium	0.7
G 3/8	OMNI-VHZ-010GK	200	Stainless steel	1.7
G 3/4	OMNI-VHZ-020GA	200	Aluminium	1.8
G 3/4	OMNI-VHZO-020GA	100	Aluminium / glass	1.8
G 1	OMNI-VHZ-025GA	100	Aluminium	6.7

**Ranges**

Metering range l/min	Types	Pulse volume (= resolution) cm <sup>3</sup>
0.02.. 2	OMNI-VHZ-008	0.04
0.10.. 6	OMNI-VHZ-010	0.20
0.50.. 50	OMNI-VHZ(O)-020	2.00
3.00.. 150	OMNI-VHZ-025	5.22

**Materials**

	OMNI-VHZ-008..025GA	OMNI-VHZ-008GK	OMNI-VHZ-010..025GK
<b>Housing</b>	Al anodised	stainless steel 1.4404	stainless steel 1.4404
<b>gear-wheel and Axis</b>	stainless steel 1.4462	stainless steel 1.4462	stainless steel 1.4462
<b>Bearing</b>	Iglidur X	stainless steel 1.4037 / 1.4016 / PVD-coated	Iglidur X
<b>Seal</b>	FKM	FKM	FKM
<b>Sight glass</b>	Glass (only with VHZO)		

**Wiring**

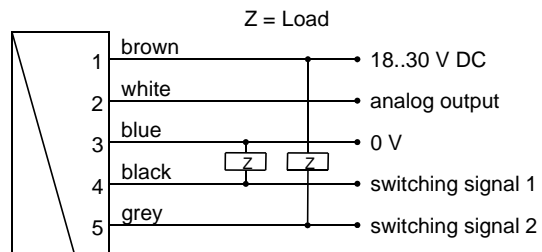

Connection example: PNP NPN

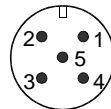

Before the electrical installation, it must be ensured that the supply voltage complies with the data sheet.  
 The use of shielded cabling is recommended.

**Product Information**

**Sensors and Instrumentation**

**Dimensions**

**OMNI-VHZ008**

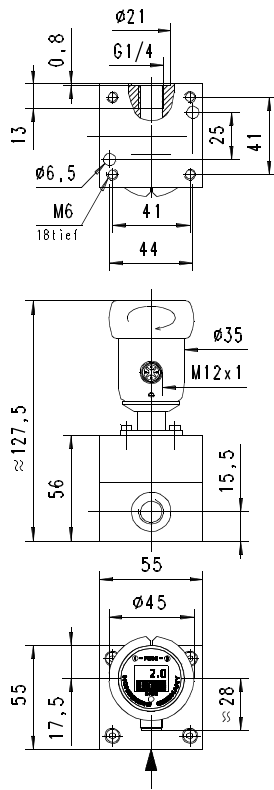

**OMNI-VHZ-020**

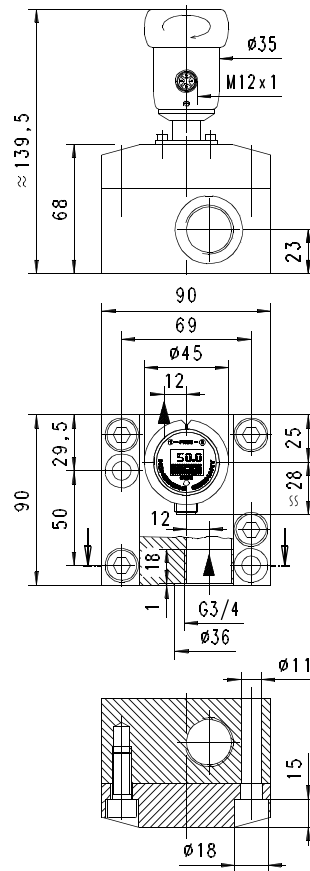

**OMNI-VHZ010**

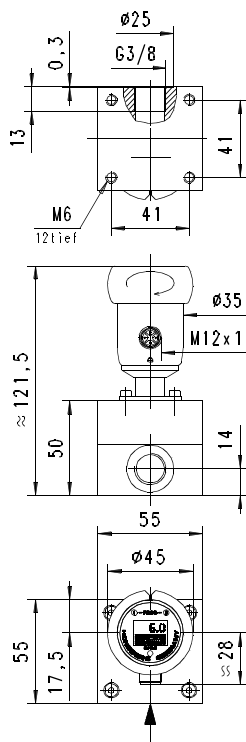

**OMNI-VHZ-025**

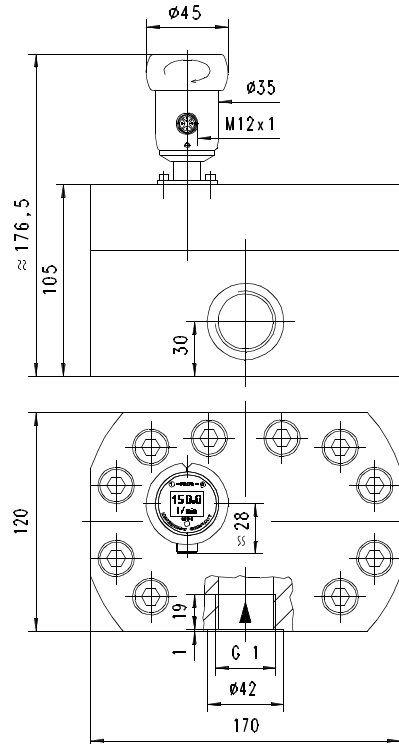

**Product Information**

**Sensors and Instrumentation**

**Gooseneck option**



A gooseneck (optional) between the electronics head and the primary sensor provides freedom in the orientation of the sensor. This option simultaneously provides thermal decoupling between the two units.

**Handling and operation**

**Installation**

The VHZ flow measurement device can be installed anywhere in the pipework system. A run-in section is not required. The direction of flow may be freely chosen.

It should be ensured that no dirt particles (thread cutting swarf) can get into the flow space, as this could cause the blockage of the gearwheels. It may therefore be necessary to install filters upstream of the flow measurement device (mesh size 30 µm).

**Programming**

The annular gap of the programming ring can be turned to positions 1 and 2. The following actions are possible:



**Set to 1 = continue (STEP)**  
**Set to 2 = modify (PROG)**

**Neutral position between 1 and 2**

The ring can be removed to act as a key, or turned through 180 ° and replaced to create a programming protector.

Operation is by dialog with the display messages, which makes its use very simple.

Starting from the normal display (present value and unit), if 1 (STEP) is repeatedly selected, then the display shows the following information in this order:

**Display of the parameters, using position 1**

- Switching value S1 (switching point 1 in the selected unit)
- Switching characteristic of S1  
 MIN = Monitoring of minimum value  
 MAX = Monitoring of maximum value
- Hysteresis 1 (hysteresis value of S1 in the set unit)
- Switching value S2
- Switching characteristic of S2
- Hysteresis 2
- Code  
 After entering the **code 111**, further parameters can be defined:
- Filter (settling time of the display and output)
- Physical unit (Units)
- Output: 0..20 mA or 4..20 mA
- 0/4 mA (measured value corresponding to 0/4 mA)
- 20 mA (measured value corresponding to 20 mA)

For models with a voltage output, replace 20 mA accordingly with 10 V.

**Edit, using position 2**

If the currently visible parameter is to be modified:

- Turn the annular gap to position 2, so that a flashing cursor appears which displays the position which can be modified.
- By repeatedly turning to position 2, values are increased; by turning to position 1, the cursor moves to the next digit.
- Leave the parameter by turning to position 1 (until the cursor leaves the row); this accepts the modification.
- If there is no action within 30 seconds, the device returns to the normal display range without accepting the modification.

The limit switches S1 and S2 can be used to monitor minima or maxima.

With a minimum-switch, falling below the limit value causes a switchover to the alarm state. Return to the normal state occurs when the limit value plus the set hysteresis is once more exceeded.

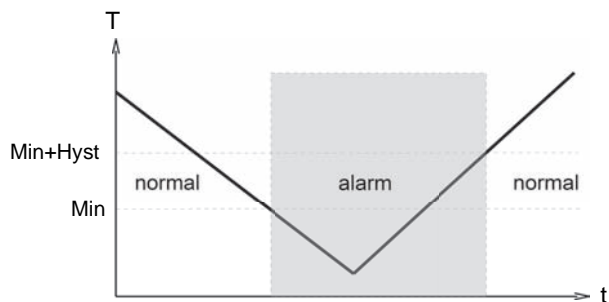

With a maximum-switch, exceeding the limit value causes a switchover to the alarm state. Return to the normal state occurs when the measured value once more falls below the limit value minus the set hysteresis.

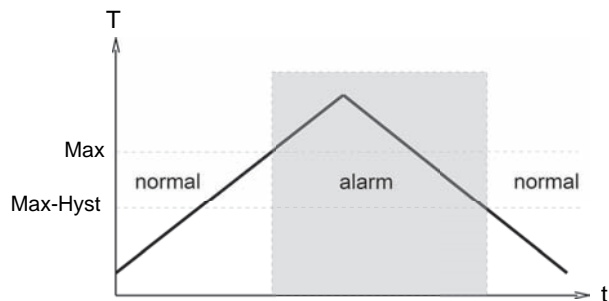

The change to the alarm state is indicated by the integrated red LED and a cleartext in the display. While in the normal state the switching outputs are at the level of the supply voltage; in the alarm state they are at 0 V, so that a wire break would also display as an alarm state at the signal receiver.

**Overload display**

Overload of a switching output is detected and indicated on the display ("Check S 1 / S 2"), and the switching output is switched off.

**Simulation mode**

To simplify commissioning, the sensor provides a simulation mode for the analog output. It is possible to create a programmable value in the range 0..26.0 mA at the output (without modifying the process variable). This allows the wiring run between the sensor and the downstream electronics to be tested during commissioning. This mode is accessed by means of **Code 311**.

**Factory settings**

After modifying the configuration parameters, it is possible to reset them to the factory settings at any time using **Code 989**.

**Product Information**

**Sensors and Instrumentation**

**Ordering code**

The base device is ordered, e.g. VHZ-008GA002E with electronics, e.g. OMNI-VHZ-008ILO

VHZ-

OMNI-VHZ-

○=Option

**Accessories**

- Cable/round plug connector (KB...) see additional information "Accessories"
- Device configurator ECI-1

<b>1. Sight glass</b>					
-	no sight glass				
O-	with sight glass				
<b>2. Nominal width</b>					
008	DN 8 - G 1/4				●
010	DN 10 - G 3/8				●
020	DN 20 - G 3/4				● ●
025	DN 25 - G 1				●
<b>3. Process connection</b>					
G	female thread				
<b>4. Body material</b>					
A	aluminium		●	●	● ●
K	<input type="radio"/> stainless steel				● ●
<b>5. Ranges</b>					
002	0.02.. 2 l/min				●
006	0.10.. 6 l/min				●
050	0.50.. 50 l/min		●		
150	3.00..150 l/min		●		
<b>6. Connection for</b>					
E	electronics		●	●	● ●
<b>7. For base device</b>					
008	VHZ-008G....E				●
010	VHZ-010G....E				●
020	VHZ(O)-020G....E			●	
025	VHZ-025G....E		●		
<b>8. Analog output</b>					
I	current output 4..20 mA				
U	voltage output 0..10 V				
<b>9. Electrical connection</b>					
S	for round plug connector M12x1, 5-pole				
<b>10. Option</b>					
H	<input type="radio"/> gooseneck				
O	<input type="radio"/> tropical model				
	<input type="radio"/> Oil-filled version for heavy duty or external use				

## OMNI-C-VHZ Counter



- Simple totalisation
- Simple filling counter with programmable end signal
- Control switchover at present value
- The counter is generally supplied connected directly to the appropriate sensor.
- Automatic, dynamic change of displayed unit and decimal places in the graphics display
- Antivalent outputs
- Simple guided menu via graphics display
- Very compact dimensions
- Full metal housing with high protection class
- Rotatable head for optimum reading direction
- Simple installation

### Characteristics

The VHZ gearwheel flow meter measures the flow by a volumetric principle, in which a pair of gearwheels is moved proportional to the flow rate. The movement of the gearwheels is measured through the enclosing housing wall by a sensor. The devices are suitable for viscous, fluid, self-lubricating media, as well as for aqueous fluids such as soaps, pasts, emulsions etc. which have a non-abrasive character. Because of the volumetric functioning principle, the devices are almost completely independent of viscosity.

The totaliser of the OMNI flow rate system enables a totalisation or measurement of consumption for all HONSBERG device families (for fluids and gases) with which the OMNI system is compatible; this is independent of the input signal, pulse or analog input, and of the measurement process.

Simple filling control is also possible. Here, the counter can be set to count upwards or downwards.

When the preset point is reached, a switching signal is emitted which is available in antivalent form to two outputs.

Resetting can be carried out by means of a signal input or also by a programming ring.

The state of the counter is indicated in an LCD display with only four digits. Here, the number of decimal places and the unit displayed is continuously matched to the current state of the counter. In this case, the smallest value which can be displayed is 0.001 ml (= 1 µl), and the largest is 9999 m<sup>3</sup>. The counter therefore has 13 places, of which the four most significant are displayed at any time.

The display resolution at all times is therefore at least 1 per thousand of the displayed value, or better, and this generally exceeds the accuracy of the connected flow transmitter. The non-displayed digits of the counter are in that case irrelevant to the accuracy of the measurement. The automatic dynamic changeover of units in the display in relation to the state of the counter makes the value easy to read in spite of a display with only four digits. In addition, user configuration of the counter is unnecessary.

In addition to the totalised value, the present flow rate can be displayed.

The stainless steel case has a hardened non-scratch mineral glass pane. It is operated by a programming ring fitted with a magnet, so there is no need to open the operating controls housing, and its leakproofness is permanently ensured.

By turning the ring to right or left, it is simple to modify the parameters (e.g. switching point, hysteresis...). To protect from unintended programming, it can be removed, turned through 180 ° and replaced, or completely removed, thus acting as a key.



### Technical data

<b>Sensor</b>	gearwheel volumeter	
<b>Nominal width</b>	DN 8..25	
<b>Process connection</b>	female thread G 1/4..G 1	
<b>Metering ranges</b>	0.02..150 l/min for details, see table "Ranges"	
<b>Measurement accuracy</b>	±3 % of the measured value in the specified metering range (measured at 20 mm <sup>2</sup> /s)	
<b>Repeatability</b>	±0.3 %	
<b>Medium temperature</b>	-25..+80 °C optionally -25..+120 °C	
<b>Ambient temperature</b>	-20..+70 °C	
<b>Pressure resistance</b>	see table "Pressure resistance and weight"	
<b>Pressure loss</b>	see upstream page "Function and benefits - volumetric, gearwheel"	
<b>Materials medium-contact</b>	see table "Materials"	
<b>Materials non-medium-contact</b>	Electronics housing	stainless steel 1.4305
	Glass	mineral glass, hardened
	Magnet	samarium-Cobalt
	Ring	POM
	Adapter	CW614N nickelled
<b>Counter range</b>	0.000 ml to 9999 m <sup>3</sup> with automatic setting for decimal places and the appropriate unit.	
<b>Switching signal outputs (Pin 4 + 5)</b>	2 x push-pull output, max. 100 mA, resistant to short circuits, and reversed polarity protected antivalent states, configurable on the device as a wipe or edge signal	
<b>Counter reset signal (Pin 2)</b>	input 18..30 V resistant to short circuits and polarity reversal, wiper signal, positive or negative edge can be selected locally	
<b>Counting input</b>	(normally not directly accessible from the device) frequency input 0..10 kHz analog input 0/4..20 mA analog input 0..10 V	
<b>Supply voltage</b>	18..30 VDC	

**Product Information**

**Sensors and Instrumentation**

<b>Power consumption</b>	< 1 W
<b>Display</b>	backlit graphical LCD-Display (transreflective), extended temperature range -20..+70 °C, 32 x 16 pixels, background illumination, displays value and unit, flashing LED signal lamp with simultaneous message on the display.
<b>Electrical connection</b>	for round plug connector M12x1, 5-pole
<b>Ingress protection</b>	IP 67 / (IP 68 when oil-filled)
<b>Weight</b>	see table "Pressure resistance and weight"
<b>Conformity</b>	CE

**Pressure resistance and weight**

G	Types	PN	Housing material	Weight kg
G 1/4	OMNI-C-VHZ-008GA	200	Aluminium	0.7
G 1/4	OMNI-C-VHZ-008GK	160	Stainless steel	1.7
G 3/8	OMNI-C-VHZ-010GA	200	Aluminium	0.7
G 3/8	OMNI-C-VHZ-010GK	200	Stainless steel	1.7
G 3/4	OMNI-C-VHZ-020GA	200	Aluminium	1.8
G 3/4	OMNI-C-VHZO-020GA	100	Aluminium / glass	1.8
G 1	OMNI-C-VHZ-025GA	100	Aluminium	6.7

**Ranges**

Metering range l/min	Types	Pulse volume (= resolution) cm <sup>3</sup>
0.02.. 2	OMNI-C-VHZ-008	0.04
0.10.. 6	OMNI-C-VHZ-010	0.20
0.50.. 50	OMNI-C-VHZ(O)-020	2.00
3.00..150	OMNI-C-VHZ-025	5.22

**Materials**

	OMNI-C-VHZ-008..025GA	OMNI-C-VHZ-008GK	OMNI-C-VHZ-010..025GK
<b>Housing</b>	Al anodised	Stainless steel 1.4404	Stainless steel 1.4404
<b>gear-wheel and Axis</b>	stainless steel 1.4462	Stainless steel 1.4462	Stainless steel 1.4462
<b>Bearing</b>	Iglidur X	Stainless steel 1.4037 / 1.4016 / PVD-coated	Iglidur X
<b>Seal</b>	FKM	FKM	FKM
<b>Sight glass</b>	glass (only with VHZO)		

**Wiring**

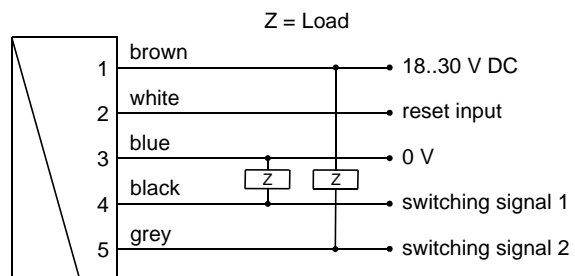

Connection example: PNP NPN

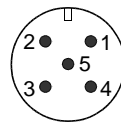

Before the electrical installation, it must be ensured that the supply voltage corresponds to the data sheet.

The use of shielded cabling is recommended.



## Product Information

## Sensors and Instrumentation

### Gooseneck option



A gooseneck (optional) between the electronics head and the primary sensor provides freedom in the orientation of the sensor. This option simultaneously provides thermal decoupling between the two units.

## Handling and operation

### Installation

The VHZ flow measurement device can be installed anywhere in the pipework system. A run-in section is not required. The direction of flow may be freely chosen. It should be ensured that no dirt particles (thread cutting swarf) can get into the flow space, as this could cause the blockage of the gearwheels.

It may therefore be necessary to install filters upstream of the flow measurement device (mesh size 30 µm).

### Programming

On the display, the counter indicates the state of the totaliser as a value and unit. The units ml, L, m<sup>3</sup> are set automatically.

For operation as a totaliser, no configuration by the user is necessary.

To use the other functions, configuration may be required. This is carried out using the programming ring located on the device.

The annular gap of the programming ring can be turned to positions 1 and 2. The following actions are possible:



**Set to 1 = continue (STEP)**  
**Set to 2 = modify (PROG)**

**Neutral position between 1 and 2**

The ring can be removed to act as a key, or turned through 180 ° and replaced to create a programming protector. Operation is by dialog with the display messages, which makes its use very simple.

The control display of the present flow rate depends on the metering range of the selected flow transmitter, and has already been set appropriately in the factory (ml/min, l/min, l/h, m<sup>3</sup>/h). It is activated by turning the ring to position 1. After 10 seconds, the display automatically returns to the totaliser mode.

For operation as a preset counter, the following must be set:

1. The preset point
2. The type of output signal ("Preset has been reached"):  
Signal edge / wiper pulse  
width of the wiper pulse, if required
3. The unit of the preset point:  
(ml, litre, m<sup>3</sup>).

Starting from the normal display (total and unit), if 1 (STEP) is selected repeatedly, then the counter shows the following information:

- Normal display is total and unit (e.g. litre)
- Display of present value (e.g. l/min)
- Preset point incl. type of switching output.
- Code

The code gives access to various input levels into which parameters can be entered (so that this does not occur unintentionally, the code must be entered).

### Code 111:

- Gate time (available only for sensors which transmit frequency)
- Filter time
- Direction of count (pos. / neg.)
- Unit for switching value/reset point
- Decimal place for switching value/reset point
- Switching type for switching value (edge/wiper signal)
- Pulse duration (for wiper signal)
- Reset method (manual / via signal)

### Code 100:

- Manual reset for totaliser

The detailed flow chart for operation is available in the "Operating instructions for OMNI-C".



**Product Information**

**Sensors and Instrumentation**

**Ordering code**

The base device is ordered, e.g. VHZ-008GA002E with electronics, e.g. OMNI-C-VHZ-008ILO

1. 2. 3. 4. 5. 6.  
 VHZ-

7. 8. 9. 10.  
 OMNI-C-VHZ-

○=Option

**Accessories**

- Round plug connector/cable
- Device configurator ECI-1

<b>1. Sight glass</b>									
-	no sight glass								
O-	with sight glass								
<b>2. Nominal width</b>									
008	DN 8 - G 1/4								●
010	DN 10 - G 3/8								●
020	DN 20 - G 3/4								● ●
025	DN 25 - G 1								●
<b>3. Process connection</b>									
G	female thread								
<b>4. Body material</b>									
A	aluminium								● ● ● ●
K	<input type="radio"/> stainless steel								● ●
<b>5. Ranges</b>									
002	0.02.. 2 l/min								●
006	0.10.. 6 l/min								●
050	0.50.. 50 l/min								●
150	3.00..150 l/min								●
<b>6. Connection for</b>									
E	electronics								● ● ● ●
<b>7. For base device</b>									
008	VHZ-008G...E								●
010	VHZ-010G...E								●
020	VHZ(O)-020G...E								●
025	VHZ-025G...E								●
<b>8. Signal output</b>									
A	antivalent switching signal (counter state reached)								
<b>9. Electrical connection</b>									
S	for round plug connector M12x1, 5-pole								
<b>10. Option</b>									
H	<input type="radio"/> gooseneck								
O	<input type="radio"/> tropical model oil-filled version for heavy duty or external use								

**Product Information**

**Sensors and Instrumentation**

**Device Configurator  
 ECI-1**



- Can be used on site for:
  - parameter modification
  - firmware update
  - adjustment of inputs and outputs
- Can be connected via USB

**Characteristics**

The device configurator ECI-1 is an interface which allows the connection of microcontroller-managed HONSBERG sensors to the USB port of a computer. Together with the Windows software "HONSBERG Device Configurator" it enables

- the modification of all the sensor's configuration settings
- the reading of measured values
- the adjustment of inputs and outputs
- firmware updates

**Technical data**

<b>Supply voltage</b>	12..30 V DC (depending on the connected sensor) and via USB
<b>Power consumption</b>	< 1 W
<b>Connection</b>	
Sensor	cable bushing M12x1, 5-pole, straight length approx. 50 cm
Lead	device connector M12x1, 5-pole
USB	USB bushing type B
<b>Operating temperature</b>	0..50 °C
<b>Storage temperature</b>	-20..+80 °C
<b>Dimensions of housing</b>	98 mm (L) x 64 mm (W) x 38 mm (H)
<b>Housing material</b>	ABS
<b>Ingress protection</b>	IP 40

**Handling and operation**

**Connection**



The device configurator is intended for temporary connection to the application. It is connected between the the existing sensor lead and the sensor. Power supply is via the supply to the sensor and the computer's USB port. When inactive (no communication), the configurator behaves completely neutrally; all signals from the sensor remain available to the application. During communication between computer and sensor, the signal wirings are separated in the configurator, so that in this state the sensor's output signals are not available.

To connect 4-pole leads without a middle hole to the installed 5-pole device connector, adapter K04-05 is included. 4-pole leads with a middle hole can be used without an adapter.

**Ordering code**

<b>Device configurator</b> (for scope of delivery, see the diagram below)	<b>ECI-1</b>
--	--------------

**Scope of delivery**

1. Device configurator ECI-1
2. USB cable
3. Adapter K04-05
4. Plug KB05G
5. Cable K05PU-02SG
6. Carrying case



**Incl. software**

**Accessories:**

<b>Mains connector 24 V DC</b> (with fitted round plug connector, 5-pole, incl. international plug set)	<b>EPWR24-1</b>
--	-----------------



**Replacement parts:**

<b>M12x1 adapter 4- / 5-pole</b>	<b>K04-05</b>
<b>PUR cable, 5-pole, shielded</b> with round plug connector M12x1	<b>K05PU-02SG</b>
<b>Round plug connector M12x1, 5-pole</b> (without cable)	<b>KB05G</b>

## Options

### LABO transmitter - Temperature up to 150 °C



All LABO transmitters can be used with electronics positioned in a separate area with media temperatures up to 150 °C.

### OMNI - Tropical model



This OMNI electronic option should be used where temperatures change quickly, or for external installations (the device is filled with oil, and thus prevents condensate formation in the electronics housing, even under adverse circumstances)

# Accessories

## Filter

Type ZV



Type ZE



The HONSBERG filters are offered for the protection of the devices from dirt or as independent components for coarse and fine filtration of liquids.

For more information, see additional product information.

## Round plug connector 4 / 5-pin



- 1 → brown
- 2 → white
- 3 → blue
- 4 → black

- 1 → brown
- 2 → white
- 3 → blue
- 4 → black
- 5 → grey

### Ordering code

#### Self-assembly

1. 2.  
**KB**

<b>1. Number of pins</b>	
04	4-pin
05	5-pin
<b>2. Connector output</b>	
G	straight
W	elbow 90 °

#### Packaged

1. 2. 3. 4. 5. 6.  
 **PU** -

<b>1. Number of pins</b>	
K	4-pin
K05	5-pin
<b>2. Cable material</b>	
PU	PUR
<b>3. Cable length</b>	
02	2 m
05	5 m
10	10 m
<b>4. Shielding</b>	
N	shielding not applied to coupling
S	shielding applied to coupling
<b>5. Connector output</b>	
G	straight
W	elbow 90 °
<b>6. Shielding</b>	
A	shielded

## Panel meter OMNI-TA



External converter with the same data as the electronics; can be mounted directly on the primary sensor, but as an external panel-mounting variant with IP 67 housing.

**Panel counter OMNI-C-TA**



External counter with the same data as the electronics; can be mounted directly on the primary sensor, but as an external panel-mounting variant with IP 67 housing.

**OMNI - Remote**



Function is identical to OMNI-suburb. Connection to the sensor is, however, made by wire, and so the measurement point and display location can be apart

**EEZ-904**



External universal counter





**Product Information**

**Sensors and Instrumentation**

**Product overview**

**„Industrial Sensors and Instrumentation“**

- Temperature
- Flow
- Level / Filling Height
- Analysis
- Humidity
- Pressure
- Weighing Instruments



**„Process Instrumentation Hygienic Design“**

- GHMadapt
- Temperature
- Flow
- Level / Filling Height
- Analysis



**“Laboratory Instrumentation”**



**„Industrial Electronics“**

- Displays / Controller
- Transmitter / Signal conditioning
- Isolating converters
- Safety and Monitoring Devices
- Power Electronics
- Calibration and Testing



**“Measuring Data Acquisition“**

- Data Logging and Monitoring
- Test Bench Measurement Technology
- Renewable Energies

